



Brief Description

Peppers A2LDSF type cable glands are for outdoor use in the appropriate Hazardous Areas with unarmoured, braided or armoured cable, where the braid or armour is to be terminated inside the enclosure. They seal on the outer jacket, and give environmental protection to IP68. They are suitable for normal industrial environments of temperature, humidity and vibration. Construction materials include steel, brass, aluminium alloy, and neoprene, nitrile and silicone rubbers. To minimise galvanic corrosion, the metallic gland components are made from similar materials. Material compatibility under chemical corrosion or attack by aggressive substance must be considered before installation.

Warning

PLEASE STUDY CAREFULLY BOTH PAGES OF THESE INSTRUCTIONS BEFORE INSTALLATION. These glands should not be used in any application other than those mentioned here, unless Peppers states in writing that the product is suitable for such application. Peppers can take no responsibility for any damage, injury or other consequential loss caused where the glands are not installed or used according to these instructions. This leaflet is not intended to advise on the selection of cable glands. Further guidance can be found in the standards listed overleaf.

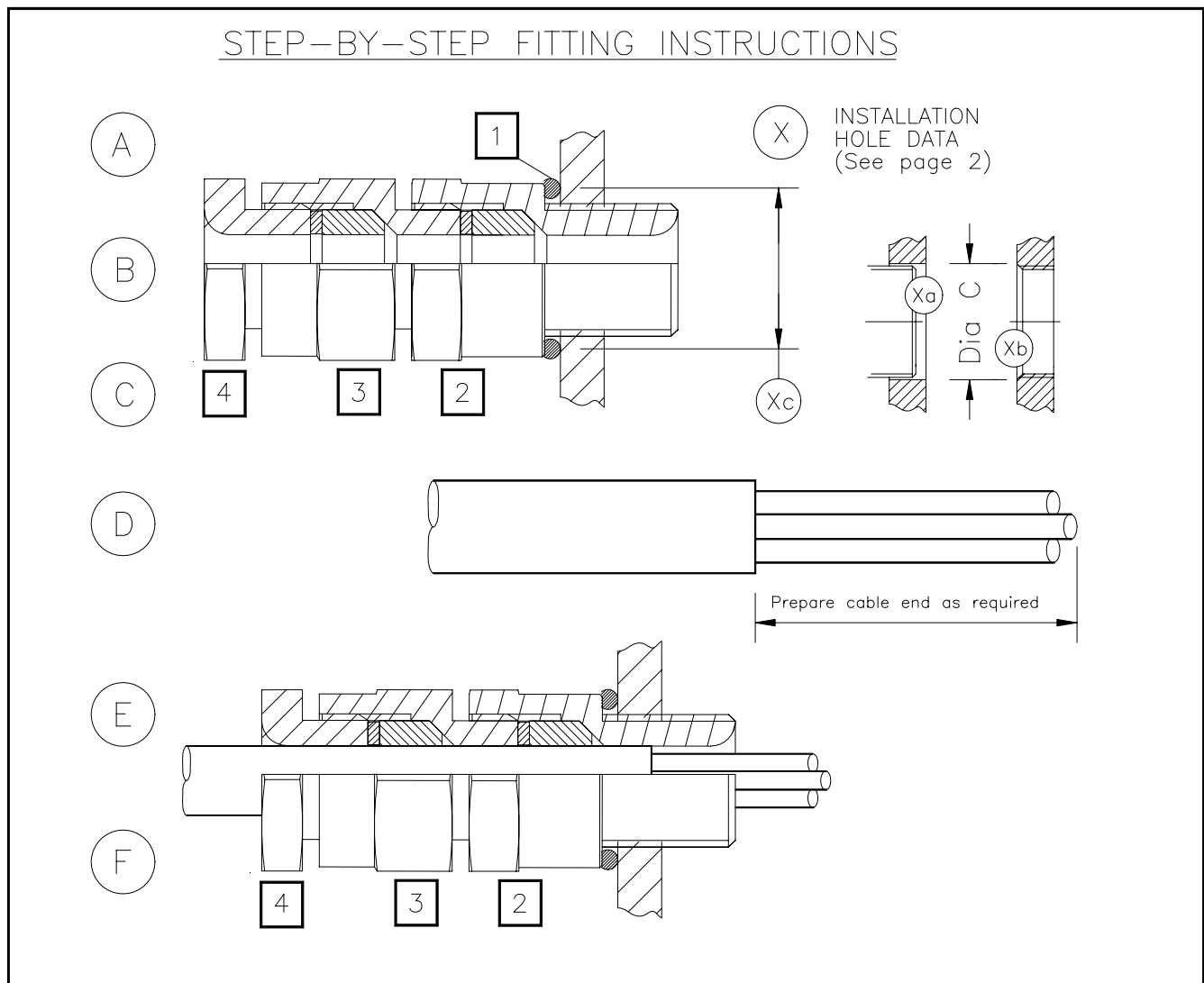

STEP-BY-STEP FITTING INSTRUCTIONS

- A** Check there is no tension in the threads.
- B** Remove [1] if not required. Fit sealing washer if required.
- C** Fit the complete cable gland to the enclosure by tightening [2]. **DO NOT EXCEED MAX TORQUE FOR THE ENCLOSURE THREAD.** At all stages, if necessary use 2nd spanner on [2] to avoid stripping enclosure thread.
- D** Prepare cable end as required.
- E** Insert cable through cable gland. Position the cable correctly. BOTH internal seals must grip the outer jacket of the cable when the cable gland is tightened.
- F** Tighten [3] to [2] and [4] to [3]. **FOR CORRECT TORQUE SEE PAGE 2.**
- X** **INSTALLATION HOLE DATA** (See page 2).
 - Xa** Diameter C for clearance holes (NOT EExd).
 - Xb** Diameter C countersinks for threaded holes (EExd).
 - Xc** Diameter O of O-ring seat.

A2LDSF Type Cable Glands - for unarmoured and braided cable - ASSEMBLY INSTRUCTIONS FOR SAFE USE

Cable Sizes (mm) & Assembly Torques (Nm)

X Hole data (see overleaf)		Gland Size	Torque Settings	Outer Sheath	
Dia O	Dia C			Min	Max
22.2	20.5	16	25.0	3.4	8.4
22.2	20.5	20S	25.0	7.2	11.7
22.2	20.5	20	25.0	9.6	14.0
27.9	25.5	25	30.0	13.5	20.0
35.5	32.5	32	32.0	19.5	26.3
43.5	40.5	40	32.0	23.0	32.2
53.5	50.5	50S	60.0	28.2	38.2
53.5	50.5	50	60.0	33.2	44.1
66.5	63.5	63S	60.0	39.3	50.1
66.5	63.5	63	60.0	46.7	56.0
78.5	75.5	75S	80.0	52.3	62.0
78.5	75.5	75	80.0	58.1	68.0
83.5	80.5	80	100.0	62.3	72.0
88.5	85.5	85	100.0	69.1	78.0
93.5	90.5	90	120.0	74.1	84.0
103.5	100.5	100	120.0	82.1	90.0

Installation Guidance

Point	Advice
1	<ul style="list-style-type: none"> ◆ BS EN 60079-10:1996 Classification of Hazardous Areas ◆ BS EN 60079-14:1997 Electrical Installations in hazardous areas (other than mines) ◆ BS 6121, Part 5:1993 Selection, Installation and Maintenance of Cable Glands
2	Installation should only be carried out by a competent electrician, skilled in cable gland installation.
3	NO INSTALLATION SHOULD BE CARRIED OUT UNDER LIVE CONDITIONS.
4	An O-ring or sealing washer should always be used with enclosures rated at above IP54. If a star washer is used, it should not be installed in such a way that it reduces the IP rating. Standard A2LDSF type glands are supplied with an O-ring. Also see page 1 diagram and Hole Data above.
5	The surface of the enclosure should be sufficiently flat and rigid to make both the IP joint, and (where necessary) a suitable earth contact. In the case of painted enclosures, a star washer should be fitted to break through the paint and make a satisfactory earth contact.
6	Once installed do not dismantle except for occasional inspection. If necessary, dismantle by reversing the instructions on page 1. The gland is not serviceable and spare parts are not supplied.
7	Parts are not interchangeable with any other design. If manufacturers' parts are mixed, certification will be invalidated.

Limitations on Usage. Be sure your installation complies with the following:-

Feature	Comment																									
Enclosure entry thread	The female thread in the enclosure must comply with clause 5.3 of EN 50018:2000, or clause 4.3 of IEC 79-1, as appropriate. Do not damage threads on assembly. Check the number of full turns of thread engaged is at least 5 (at least 6 for taper threads).																									
Cable construction	The glands should only be used with substantially round and compact cables with extruded bedding (i.e. effectively filled cables).																									
EExe/Exe enclosures	If A2LDS glands are used in a non-metallic increased safety enclosure, they must be included in the earth circuit of the system.																									
Installation conditions	<table border="1" style="width: 100%; border-collapse: collapse;"> <thead> <tr> <th>Gas Group?</th> <th>Internal Ignition Source?</th> <th>Enclosure Volume?</th> <th>Which Zone?</th> <th>Use Type A2LDS Gland?</th> </tr> </thead> <tbody> <tr> <td>IIC</td> <td>NO</td> <td>2 litres or less</td> <td>Zone 1 or 2</td> <td>YES</td> </tr> <tr> <td>IIB, IIA, II</td> <td>NO</td> <td>Any</td> <td>Zone 1 or 2</td> <td>YES</td> </tr> <tr> <td>IIB, IIA, II</td> <td>YES</td> <td>Any</td> <td>Zone 2</td> <td>YES</td> </tr> <tr> <td>IIB, IIA, II</td> <td>YES</td> <td>2 litres or less</td> <td>Zone 1</td> <td>YES</td> </tr> </tbody> </table>	Gas Group?	Internal Ignition Source?	Enclosure Volume?	Which Zone?	Use Type A2LDS Gland?	IIC	NO	2 litres or less	Zone 1 or 2	YES	IIB, IIA, II	NO	Any	Zone 1 or 2	YES	IIB, IIA, II	YES	Any	Zone 2	YES	IIB, IIA, II	YES	2 litres or less	Zone 1	YES
	Gas Group?	Internal Ignition Source?	Enclosure Volume?	Which Zone?	Use Type A2LDS Gland?																					
	IIC	NO	2 litres or less	Zone 1 or 2	YES																					
	IIB, IIA, II	NO	Any	Zone 1 or 2	YES																					
	IIB, IIA, II	YES	Any	Zone 2	YES																					
IIB, IIA, II	YES	2 litres or less	Zone 1	YES																						

Interpretation of Markings. Stampings on the outside of this gland carry the following meanings: -

Cable Gland Type & Size	
A	Gland type provides sealing to sheath and retention
2	Seal Type :- 2 = Neoprene (Temp range -20 to +80°C) 3 = Silicone (Temp range -60 to +180°C)
L	A-type gland with no separate compression bush
DS	Double seal design
F	Dual certified Flameproof/Increased Safety
20S	Gland size (typical example)
PG16	Entry thread type and size (typical example)

CENELEC Certification Markings	
E	Conformity with European Standard
Ex	Explosion Protection symbol
d	Protection type code :- d = Flameproof; e = Increased Safety
IIC	Gas Group Code suitable for Group IIC ignitable gas/air mixtures e.g. hydrogen, and also Groups IIB and IIA. II = non-ignitable (e-protection code).
SIRA	Certifying Body
01	Year of Certification
ATEX	Certified compliant with ATEX Directive 94/9/EC
1272	Certificate Serial Number
X	Special Conditions for Safe Use :- (1) These glands must not be used with EExd IIC enclosures with a volume greater than 2 litres. (2) These glands must not be used with enclosures where the temperature at the point of mounting exceeds -20° to +80°C using neoprene seals, or -60° to +180°C using silicone seals. (3) Suitable only for fixed installations. Cable must be clamped near the gland to avoid pulling and twisting

ATEX (EU Directive 94/9/EC) Markings	
	EU Explosive Atmosphere Symbol
II	Equipment Group (II = Non-Mining)
2	Equipment Category for Zones 1, 2, 21 and 22
G	For use with potentially explosive gas mixtures
D	For use with combustible dusts

Other Markings	
IP68	Ingress Protection Rating
Year Code:	XX