



# Peppers Cable Glands **Product Catalogue**



[www.cableglands.com](http://www.cableglands.com)

... whatever the hazard

# Introduction to Peppers

**Peppers Cable Glands Limited** specialise in the manufacture of cable glands for use in the hazardous locations found within Oil, Gas and Petrochemical installations.

At Peppers we have manufactured and marketed our own range of cable glands for over 62 years and have an enviable reputation for delivering quality products along with the highest possible levels of customer service and flexibility.

With the help of our distribution network, we aim to provide the global market with regular quantities of glands either from stock or within a matter of days, and project quantities within just a few weeks.

Typical users of Peppers' products include Oil and Gas operators, petrochemical and pharmaceutical companies, engineering contractors and hazardous area equipment manufacturers world-wide.

Peppers is part of the Currie & Warner Group, one of Europe's leading turned part operations, again with a global customer base.

To ensure consistent product quality Peppers work within a Quality Assurance System that is approved to ISO 9001:2000.

Due to Peppers commitment to an on-going programme of product development you may find products available which are not yet described in our catalogues. Some may also be slightly different from current descriptions. Any differences which effect safety will result in the relevant catalogue page being re-issued. The best place to check for up to date information is our website



<http://www.cableglands.com>

# Cable Gland Selection Guide

Gland Type	Outer Seal	Inner Seal	Lead Option	Armour Clamp	Certification	IP Rating	Page No.
<b>ATEX / CSA / GOST / IECEx / NEPSI Approved Glands Featuring Elastomeric Seals</b>							
CR-1	✓	✓	✓	Universal Crocklock®	Exd/Exe	Deluge, IP66,68, NEMA 4X, IEC529	1.1.0
E1WF	✓	✓	✓	✓	Exd/Exe	IP66, 67, NEMA 4X	1.2.0
CWLE	✓	×	×	✓	Exe	IP66, 67, NEMA 4X	1.3.0
A2LF	✓	×	✓	×	Exd/Exe	Deluge, IP66,68, NEMA 4X	2.1.0
A2LDSF	✓x2	×	✓	×	Exd/Exe	Deluge, IP66,68, NEMA 4X	2.2.0
A2LC*F-Conduit	✓	×	×	×	Exd/Exe	Deluge, IP66,68, NEMA 4X	2.3.0
RG22E	✓	×	×	×	Exe (ATEX Only)	IP66, 68	2.4.0
<b>ATEX / GOST / IECEx / NEPSI Approved Glands Featuring Elastomeric Seals For Flat Cable</b>							
E8XF	Flat Cable	Flat Cable	×	Braid	Exd/Exe	IP66	3.1.0
A8F	Flat Cable	×	×	×	Exd/Exe	IP68	3.2.0
<b>ATEX / CSA / GOST / IECEx / NEPSI Approved Barrier Glands</b>							
CR-C	✓	Compound	✓	Universal Crocklock®	Exd	Deluge, IP66,68, NEMA 4X, IEC529	4.1.0
CR-X	Compound	Compound	✓	×	Exd	Deluge, IP66,68, NEMA 4X	4.2.0
CR-U	✓	Compound	✓	×	Exd	Deluge, IP66,68, NEMA 4X	4.2.1
CR-S (Stopper Box)	×	Compound	×	×	Exd	Deluge, IP66,68, NEMA 4X	4.3.0
<b>UL Approved Barrier Glands</b>							
UL-C	✓	Compound	×	Universal Crocklock®	Class I Div 1 ABCD	Deluge, IP66, NEMA 4X	4.4.0
UL-U	Compound	Compound	×	×	Class I Div 2 ABCD	Deluge, IP66, NEMA 4X	4.5.0
UL-X	✓	Compound	×	×	Class I Div 2 ABCD	Deluge, IP66, NEMA 4X	4.5.1
<b>Industrial Glands Meeting the Requirements of EN50262</b>							
BW	×	×	×	✓	Industrial (BS6121)	IP30	5.1.0
CWL	✓	×	×	✓	Industrial	IP66	5.2.0
E1W	✓	✓	✓	✓	Industrial	IP67	5.3.0
A2L	✓	×	✓	×	Industrial	IP66, 68	5.4.0
<b>ACCESSORIES</b>							
AR	Adaptors & Reducers				Exd/Exe	IP66,68, NEMA 4X 6P	7.1.1
ARN	Nylon Adaptors & Reducers				Exe	IP66,68, NEMA 4X 6P	7.1.2
IA	Insulated Adaptors				Exd	IP66,68, NEMA 3	7.1.3
SPMH	Mushroom Head Stopping Plugs				Exd/Exe	IP66,68, NEMA 4X 6P	7.2.1
SPMHN	Nylon Mushroom Head Stopping Plugs				Exe	IP66,68, NEMA 4X 6P	7.2.2
SPA/SPB	Type A & Type B Stopping Plugs				Exd	IP66,68, NEMA 3	7.2.3
ACDPE	Breather Drain				Exe	IP66,68, NEMA 4X	7.3.1
GENERAL	Locknuts, Earth Tags etc.						7.4.1
<b>REFERENCE DATA</b>							
Entry Thread reference tables							I
Ingress Protection							II
Gland Weight Data							II



<b>ACCESSORIES</b>	<p>Locknut - Brass (ACBLN); 316 Stainless Steel (ACSLN)  Earth Tag - Brass (ACBET), 316 Stainless Steel (ACSET)  IP Washer - Nylon (ACNSW); Red Fibre (ACFSW)  Serrated Lock Washer - 316 Stainless Steel (ACSSW), Galvanised Steel (ACGSW)  Shroud - PVC (ACSPVC)</p> <p>Gland and accessory kits:  K1 - includes gland, locknut, earthtag, integral IP 'O' ring and PVC shroud</p> <p>Note: Glands with non metric threads are supplied with flat IP washers.</p>
--------------------	---

<b>EXAMPLE PART NUMBER</b>	<p>Sample: <b>CR-1B R K1/ZP/20S/M20</b>  <b>CR-1:</b>  CR-* - Gland type  **1 - Seal material (Neoprene)</p> <p><b>B</b> - Body material (Brass)  <b>R</b> - Reduced bore outer seal  <b>K1</b> - Supplied complete with accessories (PVC Shroud)  <b>ZP</b> - Zinc plating  <b>20s</b> - Gland size with regards to cable acceptance range  <b>M20</b> - Entry thread</p>
----------------------------	--

Gland Size	Entry Threads		Entry Thread Length	Max Across Corners	Max Protrusion Length	Gland Seal Range						Armour Acceptance Range	Shroud Size
						Cable Inner Sheath [C]		Cable Outer Sheath [D]					
	Standard							Reduced (R)					
	Min	Max				Min	Max	Min	Max				
	Metric	NPT/BSP	[B]	[A]									
16	M20	1/2" or 3/4"	16	28.0	78.0	3.4	8.4	9.0	13.5	6.7	10.3	0.15 - 1.25	L24
20s	M20	1/2" or 3/4"	16	28.0	78.0	7.2	11.7	12.9	16.0	9.4	12.5	0.15 - 1.25	L24
20	M20	1/2" or 3/4"	16	33.0	78.0	9.4	14.0	15.5	21.1	12.0	17.6	0.15 - 1.25	EL30
25	M25	3/4" or 1"	16	41.4	90.0	13.5	20.0	20.3	27.4	16.8	23.9	0.15 - 1.60	EL38
32	M32	1" or 1 1/4"	16	50.6	105.0	19.5	26.3	26.7	34.0	23.2	30.5	0.15 - 2.00	EL46
40	M40	1 1/4" or 1 1/2"	16	60.5	113.0	23.0	32.2	33.0	40.6	28.6	36.2	0.20 - 2.00	EL55
50s	M50	1 1/2" or 2"	16	71.5	125.0	28.1	38.2	39.4	46.7	34.8	42.4	0.30 - 2.50	EL65
50	M50	2"	16	71.5	125.0	33.1	44.1	45.7	53.2	41.1	48.5	0.30 - 2.50	EL65
63s	M63	2" or 2 1/2"	19	88.0	125.0	39.2	50.1	52.1	59.5	47.5	54.8	0.30 - 2.50	EL80
63	M63	2 1/2"	19	88.0	125.0	46.7	56.0	58.4	65.8	53.8	61.2	0.30 - 2.50	EL80
75s	M75	2 1/2" or 3"	19	99.0	131.0	52.1	62.0	64.8	72.2	60.2	68.0	0.30 - 2.50	EL90
75	M75	3"	19	99.0	131.0	58.0	68.0	71.1	78.0	66.5	73.4	0.30 - 2.50	EL90
80	M80 x 2	3" or 3 1/2"	25	115.2	170.0	62.2	72.0	77.0	84.0	-	-	0.45 - 3.15	L104
80H	M80 x 2	3" or 3 1/2"	25	115.2	170.0	62.2	72.0	79.6	90.0	-	-	0.45 - 3.15	L104
85	M85 x 2	3" or 3 1/2"	25	115.2	170.0	69.0	78.0	79.6	90.0	75.0	85.4	0.45 - 3.15	L104
90	M90 x 2	3 1/2" or 4"	25	125.7	170.0	74.0	84.0	88.0	96.0	-	-	0.45 - 3.15	L114
90H	M90 x 2	3 1/2" or 4"	25	125.7	170.0	74.0	84.0	92.0	102.0	-	-	0.45 - 3.15	L114
100	M100 x 2	3 1/2" or 4"	25	125.7	170.0	82.0	90.0	92.0	102.0	87.4	97.4	0.45 - 3.15	L114

All Dimensions are in mm

**NOTES:**

- Gland Size does not necessarily equate to the entry thread size
- Integral entry thread seal option is not available for glands with tapered entry threads. IP washers can be supplied if required
- Please note that dimensions (A) and (B) may differ for glands with non-Metric entry threads. Please refer to our thread data tables for specific dimensions
- Unless otherwise stated ISO Metric entry threads have a 1.5mm pitch
- For Flameproof Exd applications the female thread into which the gland is to be fitted must comply with clause 5.3 of EN 50018:2000 (clause 5.3 IEC 79-1) and an engagement of at least 5 full threads must be achieved for parallel threads and should be achieved for tapered threads
- Where CR-1 type glands are fitted into non-metallic Increased Safety Exe enclosures they must be included within the earth circuit of the system
- The user should seek expert advice if intending to combine flammable gases and combustible dusts in one environment/ installation
- Full assembly instructions are supplied with glands, the instructions must be read prior to installation and adhered to in full
- When used to terminate unarmoured cable, the gland is suitable only for fixed installations. The cable must be clamped near the gland to prevent pulling and twisting.
- In order to maintain an IP rating greater than IP54, when used in a clearance hole, a suitable IP washer is required.
- Peppers supplies cable glands with parallel entry threads which conform to the flameproof threaded joint requirements of IEC 60079-1 and other equivalent standards. They usually incorporate a thread run out according to the available machining techniques, and will not have a full-form thread for the entire length. Peppers will not be held responsible for clients' installations where this has not been taken into account.



<b>ACCESSORIES</b>	Locknut - Brass (ACBLN); 316 Stainless Steel (ACSLN) Earth Tag - Brass (ACBET), 316 Stainless Steel (ACSET) IP Washer - Nylon (ACNSW); Red Fibre (ACFSW) Serrated Lock Washer - 316 Stainless Steel (ACSSW), Galvanised Steel (ACGSW) Shroud - PVC (ACSPVC); PCP (ACSPCP); Low Smoke Zero Halogen (ACSSIO)  Gland and accessory kits: CK1 - includes gland, locknut, earthtag, fibre IP washer and PVC shroud K1 - includes gland, locknut, earthtag, nylon IP washer and PCP shroud E3WFK1 - includes brass gland, brass locknut, brass earthtag, IP washer and zero halogen shroud
--------------------	---

<b>EXAMPLE PART NUMBER</b>	Sample: <b>E1WF R CK1/ZP/20S/M20</b> <b>E1WF:</b> E*WF - Gland type, armour type (SWA) and body material (Brass) *1** - Seal material (Neoprene)  <b>R</b> - Reduced bore outer seal <b>CK1</b> - Supplied complete with accessories (PVC Shroud) <b>ZP</b> - Zinc plating <b>20s</b> - Gland size with regards to cable acceptance range <b>M20</b> - Entry thread
----------------------------	--

Gland Size	Entry Threads		Entry Thread Length [B]	Max Across Corners [A]	Max Protrusion Length	Gland Seal Range						Armour Acceptance Range		Shroud Size
						Cable Inner Sheath [C]		Cable Outer Sheath [D]						
						Standard		Reduced (R)						
	Min	Max				Min	Max	Min	Max	W	XZ			
16	M20	1/2" or 3/4"	16	26.5	58.0	4.0	8.4	8.4	13.5	4.9	10.0	0.90	0.15-0.35	L24
20s	M20	1/2" or 3/4"	16	26.5	58.0	8.0	11.7	11.5	16.0	9.4	12.5	0.90-1.25	0.15-0.35	L24
20	M20	1/2" or 3/4"	16	33.0	58.0	6.7	14.0	15.5	21.1	12.0	17.6	0.90-1.25	0.15-0.50	L30
25	M25	3/4" or 1"	16	41.4	58.0	13.0	20.0	20.3	27.4	16.8	23.9	1.25-1.60	0.15-0.50	L38
32	M32	1" or 1 1/4"	16	50.6	65.0	19.0	26.3	26.7	34.0	23.2	30.5	1.60-2.00	0.15-0.55	L46
40	M40	1 1/4" or 1 1/2"	16	60.5	72.0	25.0	32.2	33.0	40.6	28.6	36.2	1.60-2.00	0.20-0.60	L55
50s	M50	1 1/2" or 2"	16	71.5	73.0	31.5	38.2	39.4	46.7	34.8	42.4	2.00-2.50	0.20-0.60	L65
50	M50	2"	16	71.5	73.0	36.5	44.1	45.7	53.2	41.1	48.5	2.00-2.50	0.30-0.80	L65
63s	M63	2" or 2 1/2"	19	88.0	76.0	42.5	50.1	52.1	59.5	47.5	54.8	2.50	0.30-0.80	L80
63	M63	2 1/2"	19	88.0	76.0	49.5	56.0	58.4	65.8	53.8	61.2	2.50	0.30-0.80	L80
75s	M75	2 1/2" or 3"	19	99.0	82.0	54.5	62.0	64.8	72.2	60.2	68.0	2.50	0.30-1.00	L90
75	M75	3"	19	99.0	82.0	60.5	68.0	71.1	78.0	66.5	73.4	2.50	0.30-1.00	L90
80	M80 x 2	3" or 3 1/2"	25	115.2	110.0	62.2	72.0	77.0	84.0	-	-	3.15	0.45-1.00	L104
80H	M80 x 2	3" or 3 1/2"	25	115.2	110.0	62.2	72.0	79.6	90.0	-	-	3.15	0.45-1.00	L104
85	M85 x 2	3" or 3 1/2"	25	115.2	110.0	69.0	78.0	79.6	90.0	75.0	85.4	3.15	0.45-1.00	L104
90	M90 x 2	3 1/2" or 4"	25	125.7	110.0	74.0	84.0	88.0	96.0	-	-	3.15	0.45-1.00	L114
90H	M90 x 2	3 1/2" or 4"	25	125.7	110.0	74.0	84.0	92.0	102.0	-	-	3.15	0.45-1.00	L114
100	M100 x 2	3 1/2" or 4"	25	125.7	110.0	82.0	90.0	92.0	102.0	87.4	97.4	3.15	0.45-1.00	L114

**All Dimensions are in Millimetres**

**NOTES:**

- Gland Size does not necessarily equate to the entry thread size
- "W" refers to the wire diameter in a steel wire armoured cable
- "XZ" refers to the wire diameter in a woven steel wire armoured cable or the tape thickness in a steel tape armoured cable
- E3\*F gland size 20, the silicone inner seal only seals to a minimum of 11.0mm and NOT 6.7mm
- Please note that dimensions (A) and (B) may differ for glands with non-Metric entry threads. Please refer to our thread data tables for specific dimensions
- Unless otherwise stated ISO Metric entry threads have a 1.5mm pitch
- For Flameproof Exd applications the female thread into which the gland is to be fitted must comply with clause 5.3 of EN 50018:2000 (clause 5.3 IEC 79-1) and an engagement of at least 5 full threads must be achieved for parallel threads and should be achieved for tapered threads
- Where E1WF type glands are fitted into non-metallic Increased Safety Exe enclosures they must be included within the earth circuit of the system
- The user should seek expert advice if intending to combine flammable gases and combustible dusts in one environment/installation
- Full assembly instructions are supplied with glands, the instructions must be read prior to installation and adhered to in full
- In order to maintain an IP rating greater than IP54, when used in a clearance hole, a suitable IP washer is required.
- Peppers supplies cable glands with parallel entry threads which conform to the flameproof threaded joint requirements of IEC 60079-1 and other equivalent standards. They usually incorporate a thread run out according to the available machining techniques, and will not have a full-form thread for the entire length. Peppers will not be held responsible for clients' installations where this has not been taken into account.

# Peppers Cable Glands Limited

Stanhope Road, Camberley, Surrey, GU15 3BT United Kingdom  
 Telephone: +44 (0) 1276 64232  
 Facsimile: +44 (0) 1276 691752  
 Email: sales@peppers.co.uk



## Cable Gland:- Type CWLE



Including type No's:

C	*	*	L	*	*	E	*
	3	W		S	IE		R
		X					
		Z					

CWLE type glands provide a seal on the outer sheath and an armour specific armour clamp for armoured cable. The armour clamp provides an electrical bond between the cable armour and the gland. CWLE type glands maintain Increased Safety Exe methods of explosion protection and IP66.

DESIGN STANDARD	EN 50014:1998, EN 50019:2000 and EN 50281-1-1:1998	
CERTIFICATION	 ATEX II 2 GD, E Exe II GOST R-Exe II CSA Exe II 4X IECEx Ex e II NEPSI Exe II	
CERTIFICATE	SIRA 01ATEX1271 - Ex Notified Body No. 0518 POCC GB MЛ14.B00030 CSA 1356011 IECEx SIR 07.0097X NEPSI GYJ06187X	
GLAND MARKING (EXAMPLE)	Peppers GU15 3BT UK CWLE/20/M20 CA IEC Ex SIR 07.0097X Exe II/Ex tD A21 IP66 MЛ14 Sira 01ATEX1271X Ex II 2 GD EExe II	
APPLICATION	<b>EExe Equipment</b> Gas Group II, Zones 1 and 2	<b>Other Equipment</b> Ignitable Dust, Zones 21 and 22
INGRESS PROTECTION	IP66	
MATERIALS	Brass CZ121 (CWLE) 316 Stainless Steel (CWLSE) Outer sheath material: Standard (C) Neoprene, black. Option (C3) Silicone, white. Reduced outer bore sheath seal (R) Silicone, red. (CWLRL)	
VARIATIONS	Integral Earth version for HV applications: Brass (CWLIEE); 316 Stainless Steel (CWLSIEE)	
OPTIONS	THREADS	ISO Metric; NPT; NPS; ISO Pipe Thread (BSP Taper, BSP Parallel); PG
	SEALS	Extended operating temperature -60°C to +180°C, halogen free versions: Brass (C3WLE); 316 Stainless Steel (C3WLSE)
	CLAMPS	SWA steel wire armour (CWLE) SWB woven steel wire armour or STA steel tape armour (CXZLE)
	PLATING	Zinc (ZP); Nickel (NP); Tin (TP); Electroless Nickel (EN)
OPERATING TEMPERATURES	Standard Seals -20°C to +85°C Silicone Seals -60°C to +180°C	
ACCESSORIES	Locknut - Brass (ACBLN); 316 Stainless Steel (ACSLN) Earth Tag - Brass (ACBET), 316 Stainless Steel (ACSET) IP Washer - Nylon (ACNSW); Red Fibre (ACFSW) Serrated Lock Washer - 316 Stainless Steel (ACSSW), Galvanised Steel (ACGSW) Shroud - PVC (ACSPVC); PCP (ACSPCP); Low Smoke Zero Halogen (ACSSIO) Gland and accessory kits: K1- includes gland, locknut, earthtag, nylon IP washer and PVC shroud C3WLEK1 - includes brass gland, brass locknut, brass earthtag, IP washer and zero halogen shroud	

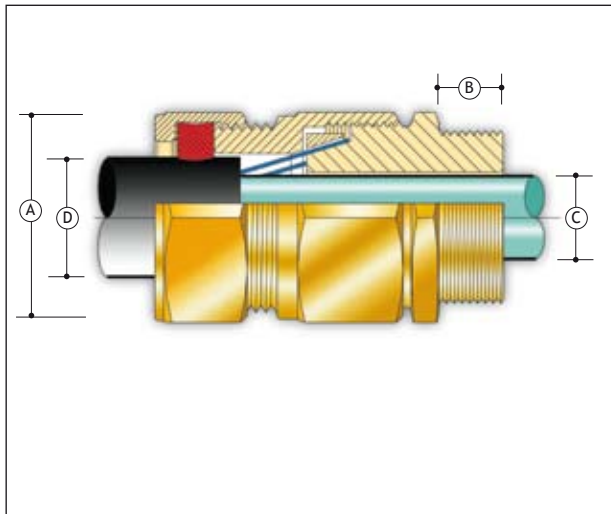

EXAMPLE PART NUMBER	<p>Sample: CWLE R K1/ZP/20S/M20</p> <p><b>CWLE:</b>          CWLE - Gland type, seal material, armour type (SWA) and body material (Brass)          C3WLE - Seal material (Silicone)</p> <p><b>R</b> - Reduced bore outer seal  <b>K1</b> - Supplied complete with accessories (PVC Shroud)  <b>ZP</b> - Zinc plating  <b>20s</b> - Gland size with regards to cable acceptance range  <b>M20</b> - Entry thread</p>
---------------------	--

Gland Size	Entry Threads		Entry Thread Length [B]	Max Across Corners [A]	Max Protrusion Length	Gland Seal Range						Armour Acceptance Range		Shroud Size
						Cable Inner Sheath [C]		Cable Outer Sheath [D]						
	Metric	NPT/BSP				Min	Max	Standard		Reduced (R)		W	XZ	
								Min	Max	Min	Max			
16	M20	1/2" or 3/4"	16	26.5	54.0	-	8.4	9.0	13.5	6.7	10.3	0.90-1.25	0.15-0.35	L24
20s	M20	1/2" or 3/4"	16	26.5	54.0	-	11.7	11.5	16.0	9.4	12.5	0.90-1.25	0.15-0.35	L24
20	M20	1/2" or 3/4"	16	33.0	54.0	-	14.0	15.5	21.0	12.0	17.6	0.90-1.25	0.15-0.50	L30
25	M25	3/4" or 1"	16	41.4	54.0	-	20.0	20.3	27.4	16.8	23.9	1.25-1.60	0.15-0.50	L38
32	M32	1" or 1 1/4"	16	50.6	60.0	-	26.3	26.7	34.0	23.2	30.5	1.60-2.00	0.15-0.55	L46
40	M40	1 1/4" or 1 1/2"	16	60.5	67.0	-	32.2	33.0	40.6	28.6	36.2	1.60-2.00	0.20-0.60	L55
50s	M50	1 1/2" or 2"	16	71.5	67.0	-	38.2	39.4	46.7	34.8	42.4	2.00-2.50	0.20-0.60	L65
50	M50	2"	16	71.5	67.0	-	44.1	45.7	53.2	41.1	48.5	2.00-2.50	0.30-0.80	L65
63s	M63	2" or 2 1/2"	19	88.0	69.0	-	50.1	52.1	59.5	47.5	54.8	2.50	0.30-0.80	L80
63	M63	2 1/2"	19	88.0	69.0	-	56.0	58.4	65.8	53.8	61.2	2.50	0.30-0.80	L80
75s	M75	2 1/2" or 3"	19	99.0	77.0	-	62.0	64.8	72.2	60.2	68.0	2.50	0.30-1.00	L90
75	M75	3"	19	99.0	77.0	-	68.0	71.1	78.0	66.5	73.4	2.50	0.30-1.00	L90
80	M80 x 2	3" or 3 1/2"	25	115.2	104.0	-	72.0	77.0	84.0	-	-	3.15	0.45-1.00	L104
80H	M80 x 2	3" or 3 1/2"	25	115.2	104.0	-	72.0	79.6	90.0	-	-	3.15	0.45-1.00	L104
85	M85 x 2	3" or 3 1/2"	25	115.2	104.0	-	78.0	79.6	90.0	75.0	85.4	3.15	0.45-1.00	L104
90	M90 x 2	3 1/2" or 4"	25	125.7	104.0	-	84.0	88.0	96.0	-	-	3.15	0.45-1.00	L114
90H	M90 x 2	3 1/2" or 4"	25	125.7	104.0	-	84.0	92.0	102.0	-	-	3.15	0.45-1.00	L114
100	M100 x 2	3 1/2" or 4"	25	125.7	104.0	-	90.0	92.0	102.0	87.4	97.4	3.15	0.45-1.00	L114

All Dimensions are in Millimetres

**NOTES:**

- Gland Size does not necessarily equate to the entry thread size
- "W" refers to the wire diameter in a steel wire armoured cable
- "XZ" refers to the wire diameter in a woven steel wire armoured cable or the tape thickness in a steel tape armoured cable
- Please note that dimensions (A) and (B) may differ for glands with non-Metric entry threads. Please refer to our thread data tables for specific dimensions
- Unless otherwise stated ISO Metric entry threads have a 1.5mm pitch
- Where CWLE type glands are fitted into non-metallic Increased Safety Exe enclosures they must be included within the earth circuit of the system
- The user should seek expert advice if intending to combine flammable gases and combustible dusts in one environment/installation
- Full assembly instructions are supplied with glands, the instructions must be read prior to installation and adhered to in full
- In order to maintain an IP rating greater than IP54, when used in a clearance hole, a suitable IP washer is required.

<http://www.cableglands.com>



<b>ACCESSORIES</b>	<p>Locknut - Brass (ACBLN); 316 Stainless Steel (ACSLN); Aluminium (ACALN)  Earth Tag - Brass (ACBET), 316 Stainless Steel (ACSET); Aluminium (ACAET)  IP Washer - Nylon (ACNSW); Red Fibre (ACFSW)  Serrated Lock Washer - 316 Stainless Steel (ACSSW), Galvanised Steel (ACGSW)  Shroud - PVC (ACSPVC); PCP (ACSPCP); Low Smoke Zero Halogen (ACSSIO)</p> <p>Gland and accessory kits:  CK1 - includes gland, locknut, integral IP 'O' ring and PVC shroud  K1 - includes gland, locknut, integral IP 'O' ring and PCP shroud</p> <p>Note: Glands with non metric threads are supplied with flat IP washers.</p>
--------------------	--

<b>EXAMPLE PART NUMBER</b>	<p>Sample: <b>A2LF CK1/ZP/20S/M20</b>  <b>A2LF:</b>  A*LF - Gland type and body material (Brass)  *2** - Seal material (Neoprene)</p> <p><b>CK1</b> - Supplied complete with accessories (PVC Shroud)  <b>ZP</b> - Zinc plating  <b>20s</b> - Gland size with regards to cable acceptance range  <b>M20</b> - Entry thread</p>
----------------------------	--

Gland Size	Entry Threads		Entry Thread Length [B]	Max Across Corners [A]	Max Protrusion Length	Gland Seal Range		Shroud Size
	Metric	NPT/BSP				Cable Outer/Lead Sheath		
						Min	Max	
16	M20	1/2" or 3/4"	16	28.0	33.0	4.0	8.4	L24
20s	M20	1/2" or 3/4"	16	28.0	33.0	7.2	11.7	L24
20	M20	1/2" or 3/4"	16	33.0	33.0	9.6	14.0	L30
25	M25	3/4" or 1"	16	41.4	33.0	13.5	20.0	L38
32	M32	1" or 1 1/4"	16	50.6	33.0	19.5	26.3	L46
40	M40	1 1/4" or 1 1/2"	16	60.5	37.0	23.0	32.2	L55
50s	M50	1 1/2" or 2"	16	71.5	37.0	28.2	38.2	L65
50	M50	2"	16	71.5	37.0	33.2	44.1	L65
63s	M63	2" or 2 1/2"	19	88.0	37.0	39.3	50.1	L80
63	M63	2 1/2"	19	88.0	37.0	46.7	56.0	L80
75s	M75	2 1/2" or 3"	19	99.0	37.0	52.3	62.0	L90
75	M75	3"	19	99.0	37.0	58.1	68.0	L90
80	M80 x 2	3" or 3 1/2"	25	115.2	50.0	62.3	72.0	L104
85	M85 x 2	3" or 3 1/2"	25	115.2	50.0	69.1	78.0	L104
90	M90 x 2	3 1/2" or 4"	25	125.7	50.0	74.1	84.0	L114
100	M100 x 2	3 1/2" or 4"	25	125.7	50.0	82.0	90.0	L114

**All Dimensions are in Millimetres**

**NOTES:**

- Suitable only for fixed installations. The cable must be clamped near the gland to prevent pulling and twisting
- Gland Size does not necessarily equate to the entry thread size
- Integral entry thread seal option is not available for glands with tapered entry threads. IP washers can be supplied if required
- Please note that dimensions (A) and (B) may differ for glands with non-Metric entry threads. Please refer to our thread data tables for specific dimensions
- Unless otherwise stated ISO Metric entry threads have a 1.5mm pitch
- For Flameproof Exd applications the female thread into which the gland is to be fitted must comply with clause 5.3 of EN 50018:2000 (clause 5.3 IEC 79-1) and an engagement of at least 5 full threads must be achieved for parallel threads and should be achieved for tapered threads
- Where A2LF type glands are fitted into non-metallic Increased Safety Exe enclosures they must be included within the earth circuit of the system
- The user should seek expert advice if intending to combine flammable gases and combustible dusts in one environment/ installation
- Full assembly instructions are supplied with glands, the instructions must be read prior to installation and adhered to in full
- In order to maintain an IP rating greater than IP54, when used in a clearance hole, a suitable IP washer is required.
- Peppers supplies cable glands with parallel entry threads which conform to the flameproof threaded joint requirements of IEC 60079-1 and other equivalent standards. They usually incorporate a thread run out according to the available machining techniques, and will not have a full-form thread for the entire length. Peppers will not be held responsible for clients' installations where this has not been taken into account.

# Peppers Cable Glands Limited

Stanhope Road, Camberley, Surrey, GU15 3BT United Kingdom  
 Telephone: +44 (0) 1276 64232  
 Facsimile: +44 (0) 1276 691752  
 Email: sales@peppers.co.uk



## Cable Gland:- Type A2LDSF



Including type No's:

A	*	L	D	S	*	F
	2				S	
	3				A	

A2LDSF type glands provide two pull resistant seals on the outer sheath of any cable. A2LDSF type glands maintain Flameproof Exd and Increased Safety Exe methods of explosion protection and IP66, IP68 to 25 metres. An integral 'O' ring entry thread seal is fitted to metric versions as standard.

DESIGN STANDARD	EN50014:1998, EN50018:2000, EN50019:2000 and EN 50281-1-1:1998																								
CERTIFICATION	ATEX II 2 GD, E Exd IIC / E Exe II GOST R-Exd IIC/Exe II CSA Exd IIC/Exe II 4X IECEx Ex d IIC / Ex e II NEPSI Exd IIC / Exe II																								
CERTIFICATE	SIRA 01ATEX1272X - Ex Notified Body No. 0518 POCC GB MJ14.B00030 CSA 1356011 IECEx SIR 07.0096X NEPSI GYJ06186X																								
GLAND MARKING (EXAMPLE)	MJ14 Peppers GU15 3BT UK A2LDSF/20/M20 CA Sira 01ATEX1272X Ex II 2 GD EExd IIC/EEExe II IEC Ex SIR 07.0096X Exd IIC/Exe II/Ex tD A21 IP68																								
APPLICATION	<p><b>EExd Equipment</b>                  A2LDSF type glands will only maintain Flameproof Exd integrity when used with cable that is substantially round and compact with extruded bedding. The cable shall be deemed to be effectively filled. Ref: IEC60079-14:2002 Section 10.4.2</p> <table border="1"> <thead> <tr> <th>Gas Group</th> <th>Internal Ignition Source</th> <th>Enclosure Volume</th> <th>Which Zone</th> <th>Use A2LDSF Gland</th> </tr> </thead> <tbody> <tr> <td>IIC, IIB, IIA</td> <td>NO</td> <td>Any</td> <td>Zone 1 or 2</td> <td>YES</td> </tr> <tr> <td>IIB, IIA</td> <td>YES</td> <td>Any</td> <td>Zone 2</td> <td>YES</td> </tr> <tr> <td>IIB, IIA</td> <td>YES</td> <td>2 litres or less</td> <td>Zone 1</td> <td>YES</td> </tr> </tbody> </table> <p><b>EExe Equipment</b>                  Gas Group II, Zones 1 and 2</p> <p><b>Other Equipment</b>                  Ignitable Dust, Zones 21 and 22</p>					Gas Group	Internal Ignition Source	Enclosure Volume	Which Zone	Use A2LDSF Gland	IIC, IIB, IIA	NO	Any	Zone 1 or 2	YES	IIB, IIA	YES	Any	Zone 2	YES	IIB, IIA	YES	2 litres or less	Zone 1	YES
Gas Group	Internal Ignition Source	Enclosure Volume	Which Zone	Use A2LDSF Gland																					
IIC, IIB, IIA	NO	Any	Zone 1 or 2	YES																					
IIB, IIA	YES	Any	Zone 2	YES																					
IIB, IIA	YES	2 litres or less	Zone 1	YES																					
INGRESS PROTECTION	IP66 and IP68 @ 25 metres, Enclosure Type 4X																								
MATERIALS	Brass CZ121 (A2LDSF) 316 Stainless Steel (A2LDSSF) Aluminium Alloy (A2LDSAF)  Outer sheath seal material: Standard (A2LDSF) Neoprene, black. Option (A3LDSF) Silicone, white. Integral entry thread seal: Nitrile is supplied with neoprene outer seal version. Silicone is supplied with silicone outer seal version.																								
VARIATIONS	For lead sheath cables the gland is fitted with a metallic continuity washer: Brass (A4LDSF); 316 Stainless Steel (A4LDSSF)																								
OPTIONS	THREADS	ISO Metric; NPT; NPS; ISO Pipe Thread (BSP Taper, BSP Parallel); PG																							
	SEALS	Extended operating temperature -60°C to +180°C, halogen free versions: Brass (A3LDSF); 316 Stainless Steel (A3LDSSF); Aluminium (A3LDSAF)																							
	PLATING	Zinc (ZP); Nickel (NP); Tin (TP); Electroless Nickel (EN)																							
OPERATING TEMPERATURES	Standard Seals -20°C to +85°C Silicone Seals -60°C to +180°C																								

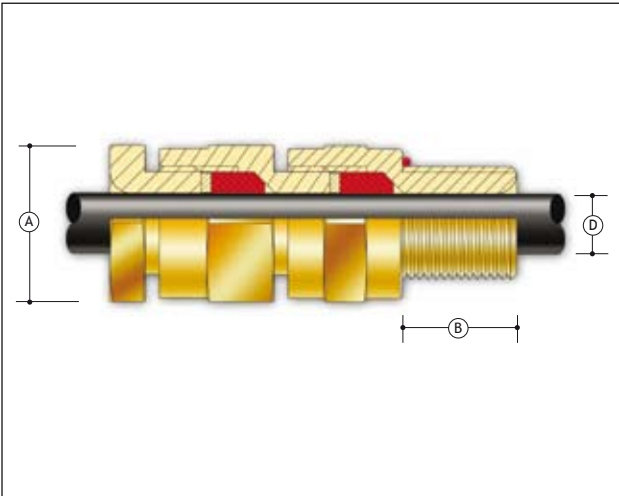

ACCESSORIES	Locknut - Brass (ACBLN); 316 Stainless Steel (ACSLN); Aluminium (ACALN) Earth Tag - Brass (ACBET), 316 Stainless Steel (ACSET); Aluminium (ACAET) IP Washer - Nylon (ACNSW); Red Fibre (ACFSW) Serrated Lock Washer - 316 Stainless Steel (ACSSW), Galvanised Steel (ACGSW) Shroud - PVC (ACSPVC); PCP (ACSPCP); Low Smoke Zero Halogen (ACSSIO)
EXAMPLE PART NUMBER	Sample: A2LDSF /ZP/20S/M20 <b>A2LDSF:</b> A*LDSF - Gland type and body material (Brass) *2**** - Seal material (Neoprene) ZP - Zinc plating 20s - Gland size with regards to cable acceptance range M20 - Entry thread

Gland Size	Entry Threads		Entry Thread Length [B]	Max Across Corners [A]	Max Protrusion Length	Gland Seal Range		Shroud Size
	Metric	NPT/BSP				Cable Outer Sheath [D]		
						Min	Max	
16	M20	1/2" or 3/4"	16	28.0	66.0	4.0	8.4	L24
20s	M20	1/2" or 3/4"	16	28.0	66.0	7.2	11.7	L24
20	M20	1/2" or 3/4"	16	29.7	66.0	9.6	14.0	L27
25	M25	3/4" or 1"	16	39.6	66.0	13.5	20.0	L36
32	M32	1" or 1 1/4"	16	45.1	66.0	19.5	26.3	L41
40	M40	1 1/4" or 1 1/2"	16	55.9	74.0	23.0	32.2	L51
50s	M50	1 1/2" or 2"	16	71.5	74.0	28.2	38.2	L65
50	M50	2"	16	71.5	74.0	33.2	44.1	L65
63s	M63	2" or 2 1/2"	19	88.0	74.0	39.3	50.1	L80
63	M63	2 1/2"	19	88.0	74.0	46.7	56.0	L80
75s	M75	2 1/2" or 3"	19	99.0	74.0	52.3	62.0	L90
75	M75	3"	19	99.0	74.0	58.1	68.0	L90
80	M80 x 2	3" or 3 1/2"	25	115.2	100.0	62.3	72.0	L104
85	M85 x 2	3" or 3 1/2"	25	115.2	100.0	69.1	78.0	L104
90	M90 x 2	3 1/2" or 4"	25	125.7	100.0	74.1	84.0	L114
100	M100 x 2	3 1/2" or 4"	25	125.7	100.0	82.0	90.0	L114

All Dimensions are in Millimetres

**NOTES:**

- Suitable only for fixed installations. The cable must be clamped near the gland to prevent pulling and twisting
- Gland Size does not necessarily equate to the entry thread size
- Integral entry thread seal option is not available for glands with tapered entry threads. IP washers can be supplied if required
- Please note that dimensions (A) and (B) may differ for glands with non-Metric entry threads. Please refer to our thread data tables for specific dimensions
- Unless otherwise stated ISO Metric entry threads have a 1.5mm pitch
- For Flameproof Exd applications the female thread into which the gland is to be fitted must comply with clause 5.3 of EN 50018:2000 (clause 5.3 IEC 79-1) and an engagement of at least 5 full threads must be achieved for parallel threads and should be achieved for tapered threads
- Where A2LF type glands are fitted into non-metallic Increased Safety Exe enclosures they must be included within the earth circuit of the system
- The user should seek expert advice if intending to combine flammable gases and combustible dusts in one environment/ installation
- Full assembly instructions are supplied with glands, the instructions must be read prior to installation and adhered to in full
- In order to maintain an IP rating greater than IP54, when used in a clearance hole, a suitable IP washer is required.
- Peppers supplies cable glands with parallel entry threads which conform to the flameproof threaded joint requirements of IEC 60079-1 and other equivalent standards. They usually incorporate a thread run out according to the available machining techniques, and will not have a full-form thread for the entire length. Peppers will not be held responsible for clients' installations where this has not been taken into account.



ACCESSORIES	Locknut - Brass (ACBLN); 316 Stainless Steel (ACSLN); Aluminium (ACALN) Earth Tag - Brass (ACBET), 316 Stainless Steel (ACSET); Aluminium (ACAET) IP Washer - Nylon (ACNSW); Red Fibre (ACFSW) Serrated Lock Washer - 316 Stainless Steel (ACSSW), Galvanised Steel (ACGSW)
-------------	--

EXAMPLE PART NUMBER	Sample: <b>A2LCFF M20/ZP/20S/M20</b> <b>A2LCFF:</b> A*LCFF - Gland type (Female connection thread) and body material (Brass) *2**** - Seal material (Neoprene) <b>M20</b> - Female connection thread <b>ZP</b> - Zinc plating <b>20s</b> - Gland size with regards to cable acceptance range <b>M20</b> - Entry thread
---------------------	---

Gland Size	Entry Threads		Entry Thread Length [B]	Max Across Corners [A]	Gland Seal Range		Conduit Connector	
	Metric	NPT/BSP			Cable Outer Sheath [D]		NPT	ISO
					Min	Max		
16	M20	1/2" or 3/4"	16	28.0	4.0	8.4	1/2" or 3/4"	M20
20s	M20	1/2" or 3/4"	16	28.0	7.2	11.7	1/2" or 3/4"	M20
20	M20	1/2" or 3/4"	16	33.0	9.6	14.0	1/2" or 3/4"	M20
25	M25	3/4" or 1"	16	41.4	13.5	20.0	3/4" or 1"	M25
32	M32	1" or 1 1/4"	16	50.6	19.5	26.3	1" or 1 1/4"	M32
40	M40	1 1/4" or 1 1/2"	16	60.5	23.0	32.2	1 1/4" or 1 1/2"	M40
50s	M50	1 1/2" or 2"	16	71.5	28.2	38.2	1 1/2" or 2"	M50
50	M50	2"	16	71.5	33.2	44.1	2"	M50
63s	M63	2" or 2 1/2"	19	88.0	39.3	50.1	2" or 2 1/2"	M63
63	M63	2 1/2"	19	88.0	46.7	56.0	2 1/2"	M63
75s	M75	2 1/2" or 3"	19	99.0	52.3	62.0	2 1/2" or 3"	M75
75	M75	3"	19	99.0	58.1	68.0	3"	M75

All Dimensions are in Millimetres

**NOTES:**

- Suitable only for fixed installations. The cable must be clamped near the gland to prevent pulling and twisting
- Gland Size does not necessarily equate to the entry thread size
- Integral entry thread seal option is not available for glands with tapered entry threads. IP washers can be supplied if required
- Please note that dimensions (A) and (B) may differ for glands with non-Metric entry threads. Please refer to our thread data tables for specific dimensions
- Unless otherwise stated ISO Metric entry threads have a 1.5mm pitch
- For Flameproof Exd applications the female thread into which the gland is to be fitted must comply with clause 5.3 of EN 50018:2000 (clause 5.3 IEC 79-1) and an engagement of at least 5 full threads must be achieved for parallel threads and should be achieved for tapered threads
- Where A2LF type glands are fitted into non-metallic Increased Safety Exe enclosures they must be included within the earth circuit of the system
- The user should seek expert advice if intending to combine flammable gases and combustible dusts in one environment/ installation
- Full assembly instructions are supplied with glands, the instructions must be read prior to installation and adhered to in full
- Other conduit connection threads eg PG, BSP are available upon request
- In order to maintain an IP rating greater than IP54, when used in a clearance hole, a suitable IP washer is required.
- Peppers supplies cable glands with parallel entry threads which conform to the flameproof threaded joint requirements of IEC 60079-1 and other equivalent standards. They usually incorporate a thread run out according to the available machining techniques, and will not have a full-form thread for the entire length. Peppers will not be held responsible for clients' installations where this has not been taken into account.

<http://www.cableglands.com>

## Peppers Cable Glands Limited

Stanhope Road, Camberley, Surrey, GU15 3BT United Kingdom  
 Telephone: +44 (0) 1276 64232  
 Facsimile: +44 (0) 1276 691752  
 Email: sales@peppers.co.uk



### Cable Gland:- Type RG22E



Including type No's: 

R	G	2	2	*	*
				U	E

RG22E type glands provide a seal on the outer sheath of unarmoured cable. RG22E type glands maintain Increased Safety Exe method of explosion protection and IP66, IP68.

DESIGN STANDARD	EN50014:1997 and EN50019:2000	
CERTIFICATION	ATEX II 2 GD, E Exe II	
CERTIFICATE	SIRA 00ATEX 1072 - Ex Notified Body No. 0518	
GLAND MARKING	Example: SIRA 00ATEX1072X EB (Cable Range)  II2GD EExell For industrial versions the hazardous area information is omitted	
APPLICATION	<b>Exe Equipment</b> Gas Group II, Zones 1 and 2	
INGRESS PROTECTION	IP66 without a sealing washer IP68 with a sealing washer	
MATERIALS	Standard (RG22E) Black Polyamide 6 Option (RG22UE) Blue Polyamide 6 Industrial, Non Ex Versions (RG22) Grey Polyamide 6 Note: Polyamide 6 is self extinguishing, flame retardant and halogen free Outer sheath seal material: Santoprene, black	
THREADS	ISO Metric; PG	
OPERATING TEMPERATURES	Sizes M25 and below: -20°C to +60°C Sizes above M25: -10°C to +60°C	
ACCESSORIES	Locknut - Nylon (ACNLN); Brass (ACBLN) IP Washer - Nylon (ACNSW); Red Fibre (ACFSW)	
EXAMPLE PART NUMBER	Sample: <b>RG22E/M20</b> <b>RG22E:</b> RG22E - Gland type, certification (Exe) and body colour, black (RG22UE, Blue)  <b>M20</b> - Gland size and entry thread	

Gland Size		Entry Thread Length	Max Across Corners	Gland Seal Range Cable Outer Sheath	
Metric	PG			Min	Max
-	7	9	16.5	3.5	6.0
M16	9	9	20.9	5.0	8.0
-	11	9	24.2	6.0	10.0
M20	13.5	10	26.4	8.0	13.5
-	16	10	28.6	10.0	15.0
M25	21	11	35.2	13.0	19.0
M32	29	12	45.1	18.0	25.0
M40	36	14	57.2	24.0	32.0
M50	42	16	64.9	29.0	38.0
M63	48	16	71.5	36.0	44.0

**All Dimensions are in Millimetres**

**NOTES:**

- Suitable only for fixed installations. The cable must be clamped near the gland to prevent pulling and twisting
- Gland sizes M25 and above shall not be used for applications where there is a "high" risk of mechanical damage
- Full assembly instructions are supplied with glands, the instructions must be read prior to installation and adhered to in full
- In order to maintain an IP rating greater than IP54, when used in a clearance hole, a suitable IP washer is required.

<http://www.cableglands.com>

# Peppers Cable Glands Limited

Stanhope Road, Camberley, Surrey, GU15 3BT United Kingdom  
 Telephone: +44 (0) 1276 64232  
 Facsimile: +44 (0) 1276 691752  
 Email: sales@peppers.co.uk



## Cable Gland:- Type E8XF



E8XF type glands provide pull resistant seals on the inner and outer sheath and a braid armour clamp. The armour clamp provides an electrical bond between the cable armour and the gland. E8XF type glands maintain Flameproof Exd and Increased Safety Exe methods of explosion protection and IP66.

DESIGN STANDARD	EN 50014:1998, EN 50018:2000, EN 50019:2000 and EN 50281-1-1:1998																						
CERTIFICATION	ATEX II 2 GD, E Exd IIC / E Exe II GOST R-Exd IIC/Exe II IECEx Ex d IIC / Ex e II NEPSI Exd IIC / Exe II																						
CERTIFICATE	SIRA 01ATEX1270X - Ex Notified Body No. 0518 POCC GB MJ14.B00030 IECEX SIR 05.0020X NEPSI GYJ06185X																						
GLAND MARKING (EXAMPLE)	Exd IIC/Exe II/Ex tD A21 IP6 E8XF/20/M20 Peppers GU15 3BT UK MJ14 IEC Ex SIR 05.0020X Sira 01ATEX1270X Ex II 2 GD EExd IIC/EEExe II																						
APPLICATION	<p><b>EExd Equipment</b>                  E8XF type glands will only maintain Flameproof Exd integrity when used with cable that has a suitable profile and is compact with extruded bedding. The cable shall be deemed to be effectively filled. Ref: IEC60079-14:2002 Section 10.4.2</p> <table border="1"> <thead> <tr> <th>Gas Group</th> <th>Internal Ignition Source</th> <th>Enclosure Volume</th> <th>Which Zone</th> <th>Use E8XF Gland</th> </tr> </thead> <tbody> <tr> <td>IIC, IIB, IIA</td> <td>NO</td> <td>2 litres or less</td> <td>Zone 1 or 2</td> <td>YES</td> </tr> <tr> <td>IIB, IIA</td> <td>YES</td> <td>Any</td> <td>Zone 2</td> <td>YES</td> </tr> <tr> <td>IIB, IIA</td> <td>YES</td> <td>2 litres or less</td> <td>Zone 1</td> <td>YES</td> </tr> </tbody> </table> <p><b>EExe Equipment</b> Gas Group II, Zones 1 and 2      <b>Other Equipment</b> Ignitable Dust, Zones 21 and 22</p>			Gas Group	Internal Ignition Source	Enclosure Volume	Which Zone	Use E8XF Gland	IIC, IIB, IIA	NO	2 litres or less	Zone 1 or 2	YES	IIB, IIA	YES	Any	Zone 2	YES	IIB, IIA	YES	2 litres or less	Zone 1	YES
Gas Group	Internal Ignition Source	Enclosure Volume	Which Zone	Use E8XF Gland																			
IIC, IIB, IIA	NO	2 litres or less	Zone 1 or 2	YES																			
IIB, IIA	YES	Any	Zone 2	YES																			
IIB, IIA	YES	2 litres or less	Zone 1	YES																			
INGRESS PROTECTION	IP66																						
MATERIALS	Brass CZ121 (E8XF) 316 Stainless Steel (E8XSF) Inner and Outer sheath seal material: Standard Silicone, red or white																						
OPTIONS	THREADS	ISO Metric; NPT; NPS; ISO Pipe Thread (BSP Taper, BSP Parallel); PG																					
	PLATING	Zinc (ZP); Nickel (NP); Tin (TP); Electroless Nickel (EN)																					
OPERATING TEMPERATURES	-60°C to +180°C																						
ACCESSORIES	Locknut - Brass (ACBLN); 316 Stainless Steel (ACSLN) Earth Tag - Brass (ACBET), 316 Stainless Steel (ACSET) IP Washer - Nylon (ACNSW); Red Fibre (ACFSW) Serrated Lock Washer - 316 Stainless Steel (ACSSW), Galvanised Steel (ACGSW)																						

EXAMPLE PART NUMBER	Sample: E8XF /ZP/20S/M20 <b>E8XF:</b> E8XF - Gland type and body material (Brass) <b>ZP</b> - Zinc plating <b>20s</b> - Gland size with regards to cable acceptance range <b>M20</b> - Entry thread
---------------------	--

Gland Size	Entry Threads	Entry Thread Length [B]	Max Across Corners [A]	Max Protrusion Length	Gland Seal Range								Armour Acceptance Range
					Cable Inner Sheath [C]				Cable Outer Sheath [D]				
	Width				Thickness		Width		Thickness				
	Min				Max	Min	Max	Min	Max	Min	Max		
20s	M20	16	26.5	58.0	6.3	11.7	4.0	7.0	7.9	11.7	4.5	7.0	0.1-0.30
20R	M20	16	33.0	58.0	8.1	13.5	5.8	6.2	7.5	16.1	3.0	8.3	0.1-0.45
20	M20	16	33.0	58.0	10.3	13.5	5.6	9.0	11.0	13.5	4.5	9.0	0.1-0.30

All Dimensions are in Millimetres

**NOTES:**

- Gland Size does not necessarily equate to the entry thread size
- "X" refers to the wire diameter in a braided cable
- Please note that dimensions (A) and (B) may differ for glands with non-Metric entry threads. Please refer to our thread data tables for specific dimensions
- Unless otherwise stated ISO Metric entry threads have a 1.5mm pitch
- For Flameproof Exd applications the female thread into which the gland is to be fitted must comply with clause 5.3 of EN 50018:2000 (clause 5.3 IEC 79-1) and an engagement of at least 5 full threads must be achieved for parallel threads and should be achieved for tapered threads
- Where E8XF type glands are fitted into non-metallic Increased Safety Exe enclosures they must be included within the earth circuit of the system
- The user should seek expert advice if intending to combine flammable gases and combustible dusts in one environment/installation
- Full assembly instructions are supplied with glands, the instructions must be read prior to installation and adhered to in full
- In order to maintain an IP rating greater than IP54, when used in a clearance hole, a suitable IP washer is required.
- Peppers supplies cable glands with parallel entry threads which conform to the flameproof threaded joint requirements of IEC 60079-1 and other equivalent standards. They usually incorporate a thread run out according to the available machining techniques, and will not have a full-form thread for the entire length. Peppers will not be held responsible for clients' installations where this has not been taken into account.

<http://www.cableglands.com>



EXAMPLE PART NUMBER	Sample: <b>A8F /ZP/20S/M20</b> <b>A8F:</b> A8F - Gland type and body material (Brass) <b>ZP</b> - Zinc plating <b>20s</b> - Gland size with regards to cable acceptance range <b>M20</b> - Entry thread
---------------------	--

Gland Size	Entry Threads	Entry Thread Length [B]	Max Across Corners [A]	Gland Seal Range Cable Outer Sheath [D]			
				Width		Thickness	
	Metric			Min	Max	Min	Max
20s	M20	16	26.5	6.3	11.7	4.0	7.0
20R	M20	16	33.0	8.1	13.5	5.8	6.2
20	M20	16	33.0	10.3	13.5	5.6	9.0

All Dimensions are in Millimetres

**NOTES:**

- Suitable only for fixed installations. The cable must be clamped near the gland to prevent pulling and twisting
- Gland Size does not necessarily equate to the entry thread size
- Integral entry thread seal option is not available for glands with tapered entry threads. IP washers can be supplied if required
- Please note that dimensions (A) and (B) may differ for glands with non-Metric entry threads. Please refer to our thread data tables for specific dimensions
- Unless otherwise stated ISO Metric entry threads have a 1.5mm pitch
- For Flameproof Exd applications the female thread into which the gland is to be fitted must comply with clause 5.3 of EN 50018:2000 (clause 5.3 IEC 79-1) and an engagement of at least 5 full threads must be achieved for parallel threads and should be achieved for tapered threads
- Where A8F type glands are fitted into non-metallic Increased Safety Exe enclosures they must be included within the earth circuit of the system
- The user should seek expert advice if intending to combine flammable gases and combustible dusts in one environment/installation
- Full assembly instructions are supplied with glands, the instructions must be read prior to installation and adhered to in full
- In order to maintain an IP rating greater than IP54, when used in a clearance hole, a suitable IP washer is required.
- Peppers supplies cable glands with parallel entry threads which conform to the flameproof threaded joint requirements of IEC 60079-1 and other equivalent standards. They usually incorporate a thread run out according to the available machining techniques, and will not have a full-form thread for the entire length. Peppers will not be held responsible for clients' installations where this has not been taken into account.

<http://www.cableglands.com>

# Peppers Cable Glands Limited

Stanhope Road, Camberley, Surrey, GU15 3BT United Kingdom  
 Telephone: +44 (0) 1276 64232  
 Facsimile: +44 (0) 1276 691752  
 Email: sales@peppers.co.uk



## Barrier Gland:- Type CR-C



Including type No's:

C	R	C	*	*
			B	R
			S	

Croclock CR-C type glands provide a Flameproof EExd compound filled barrier, a seal on the outer sheath, a universal armour clamp for armoured, screened or braided cable and an entry thread seal. The armour clamp provides an electrical bond between the cable armour, screen or braid and the gland. Croclock CR-C type glands maintain EExd Flameproof method of explosion protection; IP66, 68 to 100 metres and is deluge resistant.

DESIGN STANDARD	EN50014:1998, EN50018:2000 & EN 50281-1-1:1998 IEC 60079-0 (2000-06), IEC 60079-1 (2001-02)														
CERTIFICATION	<ul style="list-style-type: none"> <li>ATEX I M2 II 2 GD, E Exd I &amp; IIC</li> <li>GOST R-Exd I &amp; IIC</li> <li>CSA Exd I &amp; IIC 4X</li> <li>CSA A Exd IIC / A Exe II 4X, Class 1, Zone 1</li> <li>IECEx Exd IIC / Exd I</li> <li>NEPSI Exd IIC / Exe II</li> </ul>														
CERTIFICATE	SIRA 03ATEX1479X - Ex Notified Body No. 0518 POCC GB 06.B00420 CSA 1356011 IECEx SIR 07.0098X NEPSI GYJ06188X														
GLAND MARKING (EXAMPLE)	IEC Ex SIR 07.0098X Exd I & IIC Ex tD A21 IP68 CR-CB/20/M20 Sira 03ATEX1479X Peppers GU15 3BT UK ГБ06 c us Cl I Zn 1 AEx d IIC 4X EExd I & IIC Ex I M2 II 2 GD														
APPLICATION	<p><b>EExd Equipment</b>                  CR-C type glands will maintain Flameproof Exd integrity when used with any armoured or unarmoured cable types.                  Ref: IEC60079-14:2002 Section 10.4.2</p> <table border="1"> <thead> <tr> <th>Gas Group</th> <th>Internal Ignition Source</th> <th>Enclosure Volume</th> <th>Which Zone</th> <th>Use CR-C Gland</th> </tr> </thead> <tbody> <tr> <td>I, IIC, IIB, IIA</td> <td>YES</td> <td>Any</td> <td>Zone 1 or 2</td> <td>YES</td> </tr> </tbody> </table> <p><b>Other Equipment</b>                  Mining Equipment Group I, M2                  Ignitable Dust, Zones 21 and 22</p>					Gas Group	Internal Ignition Source	Enclosure Volume	Which Zone	Use CR-C Gland	I, IIC, IIB, IIA	YES	Any	Zone 1 or 2	YES
Gas Group	Internal Ignition Source	Enclosure Volume	Which Zone	Use CR-C Gland											
I, IIC, IIB, IIA	YES	Any	Zone 1 or 2	YES											
INGRESS PROTECTION	IP66 & IP68 @ 100 metres, Enclosure Type 4X, BS EN 60529 & IEC 529 Meets the requirements of DTS01 1991														
CURING TIME	@ 21°C Conductor termination can be effected after 1 hour The equipment can be energised after 4 hours The compound chamber can be inspected after 4 hours														
VARIATIONS	For lead sheath cables the gland is fitted with a metallic continuity washer: Brass (CR-C2B); Stainless Steel (CR-C2S)														
MATERIALS	Brass CZ121 (CR-CB) 316 Stainless Steel (CR-CS)  Inner LSOH compound Standard outer sheath seal is LSOH silicone, white (CR-C*) Reduced bore outer sheath seal is LSOH silicone, red (CR-C*R)  Entry thread seal: Red LSOH silicone														
OPTIONS	THREADS	ISO Metric; NPT; NPS; ISO Pipe Thread (BSP Taper, BSP Parallel)													
	PLATING	Zinc (ZP); Nickel (NP); Tin (TP); Electroless Nickel (EN)													
OPERATING TEMPERATURES	- 60°C to +85°C														

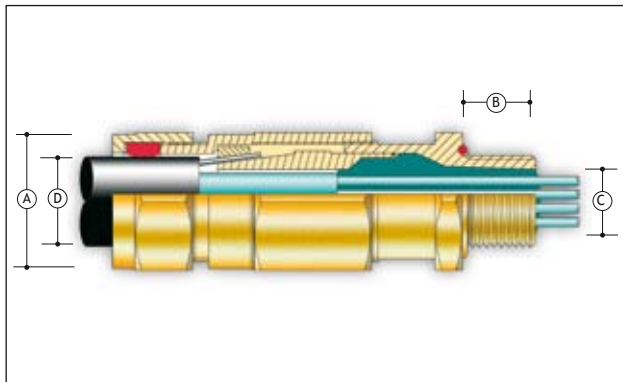

<b>ACCESSORIES</b>	<p>Locknut - Brass (ACBLN); 316 Stainless Steel (ACSLN)  Earth Tag - Brass (ACBET), 316 Stainless Steel (ACSET)  IP Washer - Nylon (ACNSW); Red Fibre (ACFSW)  Serrated Lock Washer - 316 Stainless Steel (ACSSW), Galvanised Steel (ACGSW)  Shroud - PVC (ACSPVC)</p> <p>Gland and accessory kits:  K1 - includes gland, locknut, earthtag, integral IP "O" ring &amp; PVC shroud</p> <p>Note: Glands with non metric threads are supplied with flat IP washers</p>
--------------------	--

<b>EXAMPLE PART NUMBER</b>	<p>Sample: <b>CR-CB R K1/NP/20S/M20</b>  <b>CR-C:</b>  CR-C - Gland type  **-*B - Material (Brass)  R - Reduced bore outer seal  K1 - Supplied complete with accessories (PVC Shroud)  NP - Nickel plating  20s - Gland size with regards to cable acceptance range  M20 - Entry thread</p>
----------------------------	---

Gland Size	Entry Threads		Entry Thread Length [B]	Max Across Corners [A]	Max Protrusion Length	Gland Seal Range						Armour Acceptance Range	Shroud Size	
						Cable Inner Sheath / Cores [C]			Cable Outer Sheath [D]					
	Metric	NPT/BSP				Max No. of Cores	Max Over Cores	Max Inner Sheath	Standard		Reduced (R)			
									Min	Max	Min			Max
16	M20	1/2" or 3/4"	16	28.0	72.0	7	9.0	11.7	9.0	13.5	6.7	10.3	0.15 - 1.25	L24
20s	M20	1/2" or 3/4"	16	28.0	72.0	8	10.4	11.7	11.5	16.0	9.4	12.5	0.15 - 1.25	L24
20	M20	1/2" or 3/4"	16	33.0	73.0	14	12.5	14.0	15.5	21.1	12.0	17.6	0.15 - 1.25	EL30
25	M25	3/4" or 1"	16	41.4	83.0	25	17.8	20.0	20.3	27.4	16.8	23.9	0.15 - 1.60	EL38
32	M32	1" or 1 1/4"	16	50.6	103.0	50	23.5	26.3	26.7	34.0	23.2	30.5	0.15 - 2.00	EL46
40	M40	1 1/4" or 1 1/2"	16	60.5	105.0	80	28.8	32.2	33.0	40.6	28.6	36.2	0.20 - 2.00	EL55
50s	M50	2"	16	71.5	115.0	100	34.2	38.2	39.4	46.7	34.8	42.4	0.20 - 2.50	EL65
50	M50	2"	16	71.5	115.0	100	39.4	44.1	45.7	53.2	41.1	48.5	0.20 - 2.50	EL65
63s	M63	2 1/2"	19	88.0	115.0	120	44.8	50.1	52.1	59.5	47.5	54.8	0.30 - 2.50	EL80
63	M63	2 1/2"	19	88.0	115.0	120	50.0	56.0	58.4	65.8	53.8	61.2	0.30 - 2.50	EL80
75s	M75	3"	19	99.0	122.0	140	55.4	62.0	64.8	72.2	60.2	68.0	0.30 - 2.50	EL90
75	M75	3"	19	99.0	122.0	140	60.8	68.0	71.1	78.0	66.5	73.4	0.30 - 2.50	EL90
80	M80x2	3" or 3 1/2"	25	115.2	162.0	160	64.4	72.0	77.0	84.0	-	-	0.45 - 3.15	L104
85	M85x2	3" or 3 1/2"	25	115.2	162.0	180	69.8	78.0	79.6	90.0	75.0	85.4	0.45 - 3.15	L104
90	M90x2	3 1/2" or 4"	25	125.7	166.0	200	75.1	84.0	88.0	96.0	-	-	0.45 - 3.15	L114
100	M100x2	3 1/2" or 4"	25	125.7	166.0	220	80.5	90.0	92.0	102.0	87.4	97.4	0.45 - 3.15	L114

All Dimensions are in mm

**NOTES:**

- Gland Size does not necessarily equate to the entry thread size
- Integral entry thread seal option is not available for glands with tapered entry threads. IP washers can be supplied if required
- Please note that dimensions (A) & (B) may differ for glands with non-Metric entry threads. Please refer to our thread data tables for specific dimensions
- Unless otherwise stated ISO Metric entry threads have a 1.5mm pitch
- For Flameproof Exd applications the female thread into which the gland is to be fitted must comply with clause 5.3 of EN 50018:2000 (clause 5.3 IEC 79-1) and an engagement of at least 5 full threads must be achieved for parallel threads and should be achieved for tapered threads
- If CR-C type glands are fitted into non-metallic enclosures they must be included within the earth circuit of the system
- The user should seek expert advice if intending to combine flammable gases and combustible dusts in one environment/installation
- Full assembly instructions are supplied with glands, the instructions must be read prior to installation and adhered to in full
- In order to maintain an IP rating greater than IP54, when used in a clearance hole, a suitable IP washer is required.
- Peppers supplies cable glands with parallel entry threads which conform to the flameproof threaded joint requirements of IEC 60079-1 and other equivalent standards. They usually incorporate a thread run out according to the available machining techniques, and will not have a full-form thread for the entire length. Peppers will not be held responsible for clients' installations where this has not been taken into account.

# Peppers Cable Glands Limited

Stanhope Road, Camberley, Surrey, GU15 3BT United Kingdom  
 Telephone: +44 (0) 1276 64232  
 Facsimile: +44 (0) 1276 691752  
 Email: sales@peppers.co.uk



## Barrier Gland:- Type CR-X



Including type No's:

C	R	X	*
			B
			S

Croclock CR-X type glands provide a Flameproof EExd compound filled barrier and an entry thread seal. Croclock CR-X type glands maintain EExd Flameproof method of explosion protection; IP66, 68 to 100 metres and is deluge resistant.

DESIGN STANDARD	EN50014:1998, EN50018:2000 & EN 50281-1-1:1998 IEC 60079-0 (2000-06), IEC 60079-1 (2001-02)												
CERTIFICATION	ATEX I M2 II 2 GD, E Exd I & IIC GOST R-Exd I & IIC CSA Exd I & IIC/Exe II 4X CSA A Exd IIC/A Exe II 4X, Class 1, Zone 1 IECEx Exd IIC / Exd I NEPSI Exd IIC / Exe II												
CERTIFICATE	SIRA 03ATEX1479X - Ex Notified Body No. 0518 POCC GB 06.B00420 CSA 1356011 IECEX SIR 07.0098X NEPSI GYJ06188X												
GLAND MARKING (EXAMPLE)	IEC Ex SIR 07.0098X Exd I & IIC Ex tD A21 IP68 CR-XB/20/M20 Sira 03ATEX1479X Peppers GU15 3BT UK ГБ06 c us Cl I Zn 1 AEx d IIC 4X EExd I & IIC Ex I M2 II 2 GD												
APPLICATION	<b>EExd Equipment</b> CR-X type glands will maintain Flameproof Exd integrity when used with any unarmoured cable types. Ref: IEC60079-14:2002 Section 10.4.2 <table border="1"> <thead> <tr> <th>Gas Group</th> <th>Internal Ignition Source</th> <th>Enclosure Volume</th> <th>Which Zone</th> <th>Use CR-X Gland</th> </tr> </thead> <tbody> <tr> <td>I, IIC, IIB, IIA</td> <td>YES</td> <td>Any</td> <td>Zone 1 or 2</td> <td>YES</td> </tr> </tbody> </table> <b>Other Equipment</b> Mining Equipment Group I, M2 Ignitable Dust, Zones 21 and 22			Gas Group	Internal Ignition Source	Enclosure Volume	Which Zone	Use CR-X Gland	I, IIC, IIB, IIA	YES	Any	Zone 1 or 2	YES
Gas Group	Internal Ignition Source	Enclosure Volume	Which Zone	Use CR-X Gland									
I, IIC, IIB, IIA	YES	Any	Zone 1 or 2	YES									
INGRESS PROTECTION	IP66 & IP68 @ 100 metres, Enclosure Type 4X Meets the requirements of DTS01 1991												
CURING TIME	@ 21°C Conductor termination can be effected after 1 hour The equipment can be energised after 4 hours The compound chamber can be inspected after 4 hours												
MATERIALS	Brass CZ121 (CR-XB) 316 Stainless Steel (CR-XS) Inner LSOH compound Entry thread seal: Red LSOH silicone												
VARIATIONS	For lead sheath cables the gland is fitted with a metallic continuity washer: Brass (CR-X2B); 316 Stainless Steel (CR-X2S)												
OPTIONS	THREADS	ISO Metric; NPT; NPS; ISO Pipe Thread (BSP Taper, BSP Parallel)											
	PLATING	Zinc (ZP); Nickel (NP); Tin (TP); Electroless Nickel (EN)											
OPERATING TEMPERATURES	-60°C to +85°C												

<b>ACCESSORIES</b>	<p>Locknut - Brass (ACBLN); 316 Stainless Steel (ACSLN)  Earth Tag - Brass (ACBET), 316 Stainless Steel (ACSET)  IP Washer - Nylon (ACNSW); Red Fibre (ACFSW)  Serrated Lock Washer - 316 Stainless Steel (ACSSW), Galvanised Steel (ACGSW)  Shroud - PVC (ACSPVC)</p> <p>Gland and accessory kits:  K1- includes gland, locknut, integral IP "O" ring &amp; PVC shroud</p> <p>Note: Glands with non metric threads are supplied with flat IP washers.</p>
--------------------	--

<b>EXAMPLE PART NUMBER</b>	<p>Sample: <b>CR-XB K1/NP/20S/M20</b></p> <p><b>CR-X:</b>  <b>CR-X</b> - Gland type  <b>**_*B</b> - Material (Brass)  <b>K1</b> - Supplied complete with accessories (PVC Shroud)  <b>NP</b> - Nickel plating  <b>20s</b> - Gland size with regards to cable acceptance range  <b>M20</b> - Entry thread</p>
----------------------------	--

Gland Size	Entry Threads		Entry Thread Length [B]	Max Across Corners [A]	Max Protrusion Length	Gland Seal Range Cable Sheath / Cores			Shroud Size
	Metric	NPT/BSP				Max No. of Cores	Max Over Cores [C]	Max Sheath Diameter [D]	
20s	M20	1/2" or 3/4"	16	28.0	42.0	8	10.4	11.7	L24
20	M20	1/2" or 3/4"	16	33.0	44.0	14	12.5	14.0	L30
25	M25	3/4" or 1"	16	41.4	48.0	25	17.8	20.0	L38
32	M32	1" or 1 1/4"	16	50.6	53.0	50	23.5	26.3	L46
40	M40	1 1/4" or 1 1/2"	16	60.5	54.0	80	28.8	32.2	L55
50	M50	2"	16	71.5	54.0	100	39.4	44.1	L65
63	M63	2 1/2"	19	88.0	55.0	120	50.0	56.0	L80
75	M75	3"	19	99.0	60.0	140	60.8	68.0	L90
80	M80x2	3" or 3 1/2"	25	115.2	80.0	160	64.4	72.0	L104
85	M85x2	3" or 3 1/2"	25	115.2	80.0	180	69.8	78.0	L104
90	M90x2	3 1/2" or 4"	25	125.7	85.0	200	75.1	84.0	L114
100	M100x2	3 1/2" or 4"	25	125.7	85.0	220	80.5	90.0	L114

All Dimensions are in mm

**NOTES:**

- Gland Size does not necessarily equate to the entry thread size
- Integral entry thread seal option is not available for glands with tapered entry threads. IP washers can be supplied if required
- Please note that dimensions (A) & (B) may differ for glands with non-Metric entry threads. Please refer to our thread data tables for specific dimensions
- Unless otherwise stated ISO Metric entry threads have a 1.5mm pitch
- For Flameproof Exd applications the female thread into which the gland is to be fitted must comply with clause 5.3 of EN 50018:2000 (clause 5.3 IEC 79-1) and an engagement of at least 5 full threads must be achieved for parallel threads and should be achieved for tapered threads
- If CR-X type glands are fitted into non-metallic enclosures they must be included within the earth circuit of the system
- The user should seek expert advice if intending to combine flammable gases and combustible dusts in one environment/installation
- Full assembly instructions are supplied with glands, the instructions must be read prior to installation and adhered to in full
- In order to maintain an IP rating greater than IP54, when used in a clearance hole, a suitable IP washer is required.
- Peppers supplies cable glands with parallel entry threads which conform to the flameproof threaded joint requirements of IEC 60079-1 and other equivalent standards. They usually incorporate a thread run out according to the available machining techniques, and will not have a full-form thread for the entire length. Peppers will not be held responsible for clients' installations where this has not been taken into account.

<http://www.cableglands.com>

# Peppers Cable Glands Limited

Stanhope Road, Camberley, Surrey, GU15 3BT United Kingdom  
 Telephone: +44 (0) 1276 64232  
 Facsimile: +44 (0) 1276 691752  
 Email: sales@peppers.co.uk



## Barrier Gland:- Type CR-U



Including type No's:

C	R	U	*
			B
			S

Croclock CR-U type glands provide a Flameproof EExd compound filled barrier, a secondary weather seal on the outer sheath and an entry thread seal. Croclock CR-U type glands maintain EExd Flameproof method of explosion protection; IP66, 68 to 100 metres and is deluge resistant.

DESIGN STANDARD	EN50014:1998, EN50018:2000 & EN 50281-1-1:1998 IEC 60079-0 (2000-06), IEC 60079-1 (2001-02)														
CERTIFICATION	ATEX I M2 II 2 GD, E Exd I & IIC GOST R-Exd I & IIC CSA Exd I & IIC 4X CSA A Exd IIC/A Exe II 4X, Class 1, Zone 1 IECEx Exd IIC / Exd I NEPSI Exd IIC / Exe II														
CERTIFICATE	SIRA 03ATEX1479X - Ex Notified Body No. 0518 POCC GB 06.B00420 CSA 1356011 IECEX SIR 07.0098X NEPSI GYJ06188X														
GLAND MARKING (EXAMPLE)	IEC Ex SIR 07.0098X Exd I & IIC Ex tD A21 IP68 CR-UB/20/M20 Sira 03ATEX1479X Peppers GU15 3BT UK ГБ06 c us Cl I Zn 1 AEx d IIC 4X EExd I & IIC Ex I M2 II 2 GD														
APPLICATION	<b>EExd Equipment</b> CR-U type glands will maintain Flameproof Exd integrity when used with any unarmoured cable types. Ref: IEC60079-14:2002 Section 10.4.2 <table border="1"> <thead> <tr> <th>Gas Group</th> <th>Internal Ignition Source</th> <th>Enclosure Volume</th> <th>Which Zone</th> <th>Use CR-U Gland</th> </tr> </thead> <tbody> <tr> <td>I, IIC, IIB, IIA</td> <td>YES</td> <td>Any</td> <td>Zone 1 or 2</td> <td>YES</td> </tr> </tbody> </table> <b>Other Equipment</b> Mining Equipment Group I, M2 Ignitable Dust, Zones 21 and 22					Gas Group	Internal Ignition Source	Enclosure Volume	Which Zone	Use CR-U Gland	I, IIC, IIB, IIA	YES	Any	Zone 1 or 2	YES
Gas Group	Internal Ignition Source	Enclosure Volume	Which Zone	Use CR-U Gland											
I, IIC, IIB, IIA	YES	Any	Zone 1 or 2	YES											
INGRESS PROTECTION	IP66 & IP68 @ 100 metres, Enclosure Type 4X Meets the requirements of DTS01 1991														
CURING TIME	@ 21°C Conductor termination can be effected after 1 hour The equipment can be energised after 4 hours The compound chamber can be inspected after 4 hours														
MATERIALS	Brass CZ121 (CR-UB) 316 Stainless Steel (CR-US)  Inner LSOH compound Standard outer sheath seal is LSOH silicone, white (CR-U*)  Entry thread seal: Red LSOH silicone														
VARIATIONS	For lead sheath cables the gland is fitted with a metallic continuity washer: Brass (CR-U2B); 316 Stainless Steel (CR-U2S)														
OPTIONS	THREADS	ISO Metric; NPT; NPS; ISO Pipe Thread (BSP Taper, BSP Parallel)													
	PLATING	Zinc (ZP); Nickel (NP); Tin (TP); Electroless Nickel (EN)													
OPERATING TEMPERATURES	-60°C to +85°C														

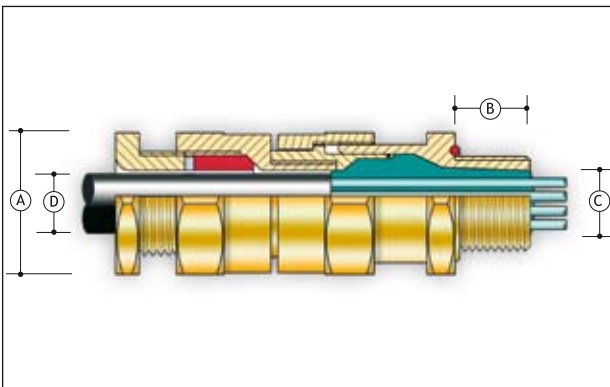

<b>ACCESSORIES</b>	<p>Locknut - Brass (ACBLN); 316 Stainless Steel (ACSLN)  Earth Tag - Brass (ACBET), 316 Stainless Steel (ACSET)  IP Washer - Nylon (ACNSW); Red Fibre (ACFSW)  Serrated Lock Washer - 316 Stainless Steel (ACSSW), Galvanised Steel (ACGSW)  Shroud - PVC (ACSPVC)</p> <p>Gland and accessory kits:  K1- includes gland, locknut, integral IP "O" ring &amp; PVC shroud</p> <p>Note: Glands with non metric threads are supplied with flat IP washers.</p>
--------------------	--

<b>EXAMPLE PART NUMBER</b>	<p>Sample: <b>CR-UB K1/NP/20S/M20</b></p> <p><b>CR-U:</b>  <b>CR-U</b> - Gland type  <b>**.*B</b> - Material (Brass)  <b>K1</b> - Supplied complete with accessories (PVC Shroud)  <b>NP</b> - Nickel plating  <b>20s</b> - Gland size with regards to cable acceptance range  <b>M20</b> - Entry thread</p>
----------------------------	--

Gland Size	Entry Threads		Entry Thread Length [B]	Max Across Corners [A]	Max Protrusion Length	Gland Seal Range					Shroud Size
	Metric	NPT/BSP				Cable Inner Sheath / Cores [C]			Cable Outer Sheath [D]		
						Max No. of Cores	Max Over Cores	Max Inner Sheath	Min	Max	
16	M20	1/2" or 3/4"	16	28.0	73.0	7	8.4	8.4	3.4	8.4	L24
20s	M20	1/2" or 3/4"	16	28.0	73.0	8	10.4	11.7	4.8	11.7	L24
20	M20	1/2" or 3/4"	16	33.0	73.0	14	12.5	14.0	9.5	14.0	EL30
25	M25	3/4" or 1"	16	41.4	74.0	25	17.8	20.0	11.7	20.0	EL38
32	M32	1" or 1 1/4"	16	50.6	80.0	50	23.5	26.3	18.1	26.3	EL46
40	M40	1 1/4" or 1 1/2"	16	60.5	87.0	80	28.8	32.2	22.6	32.2	EL55
50s	M50	2"	16	71.5	87.0	100	34.2	38.2	28.2	38.2	EL65
50	M50	2"	16	71.5	87.0	100	39.4	44.1	33.1	44.1	EL65
63s	M63	2 1/2"	19	88.0	88.0	120	44.8	50.1	39.3	50.1	EL80
63	M63	2 1/2"	19	88.0	88.0	120	50.0	56.0	46.7	56.0	EL80
75s	M75	3"	19	99.0	97.0	140	55.4	62.0	52.3	62.0	EL90
75	M75	3"	19	99.0	97.0	140	60.8	68.0	58.0	68.0	EL90
80	M80 x 2	3" or 3 1/2"	25	115.2	123.0	160	64.4	72.0	61.9	72.0	L104
85	M85 x 2	3" or 3 1/2"	25	115.2	123.0	180	69.8	78.0	69.1	78.0	L104
90	M90 x 2	3 1/2" or 4"	25	125.7	123.0	200	75.1	84.0	74.1	84.0	L114
100	M100 x 2	3 1/2" or 4"	25	125.7	123.0	220	80.5	90.0	81.8	90.0	L114

All Dimensions are in mm

**NOTES:**

- Gland Size does not necessarily equate to the entry thread size
- Integral entry thread seal option is not available for glands with tapered entry threads. IP washers can be supplied if required
- Please note that dimensions (A) & (B) may differ for glands with non-Metric entry threads. Please refer to our thread data tables for specific dimensions
- Unless otherwise stated ISO Metric entry threads have a 1.5mm pitch
- For Flameproof Exd applications the female thread into which the gland is to be fitted must comply with clause 5.3 of EN 50018:2000 (clause 5.3 IEC 79-1) and an engagement of at least 5 full threads must be achieved for parallel threads and should be achieved for tapered threads
- If CR-U type glands are fitted into non-metallic enclosures they must be included within the earth circuit of the system
- The user should seek expert advice if intending to combine flammable gases and combustible dusts in one environment/installation
- Full assembly instructions are supplied with glands, the instructions must be read prior to installation and adhered to in full
- In order to maintain an IP rating greater than IP54, when used in a clearance hole, a suitable IP washer is required.
- Peppers supplies cable glands with parallel entry threads which conform to the flameproof threaded joint requirements of IEC 60079-1 and other equivalent standards. They usually incorporate a thread run out according to the available machining techniques, and will not have a full-form thread for the entire length. Peppers will not be held responsible for clients' installations where this has not been taken into account

# Peppers Cable Glands Limited

Stanhope Road, Camberley, Surrey, GU15 3BT United Kingdom  
 Telephone: +44 (0) 1276 64232  
 Facsimile: +44 (0) 1276 691752  
 Email: sales@peppers.co.uk







## Barrier Gland:- Type CR-S for Conduits



Including type No's:

C	R	S	*
		B	
		S	

Croclock CR-S type glands provide Flameproof EExd compound filled barrier seal on the cables individual conductors within a conduit. It also provides an entry thread seal. Croclock CR-S type glands maintain EExd Flameproof method of explosion protection; IP66, 68 to 100 metres and is deluge resistant.

DESIGN STANDARD	EN50014:1998, EN50018:2000 & EN 50281-1-1:1998 IEC 60079-0 (2000-06), IEC 60079-1 (2001-02)														
CERTIFICATION	 ATEX I M2 II 2 GD, E Exd I & IIC  GOST R-Exd I & IIC  CSA Exd I & IIC 4X  IECEX Exd IIC / Exd I  NEPSI Exd IIC / Exe II														
CERTIFICATE	SIRA 03ATEX1479X - Ex Notified Body No. 0518 POCC GB 06.B00420 CSA 1356011 IECEX SIR 07.0098X NEPSI GYJ06188X														
GLAND MARKING (EXAMPLE)	Peppers GU15 3BT UK CR-SB20/M20/M20 CA IEC Ex SIR 07.0098X Exd I & IIC/Ex tD A21 IP68 ГБ06 Sira 03ATEX1479X Ex I M2 II 2 GD EExd I & IIC														
APPLICATION	<b>EExd Equipment</b> CR-S type glands will maintain Flameproof Exd integrity. Ref: IEC60079-14:2002 Section 10.4.2 <table border="1" style="width:100%; border-collapse: collapse;"> <thead> <tr> <th>Gas Group</th> <th>Internal Ignition Source</th> <th>Enclosure Volume</th> <th>Which Zone</th> <th>Use CR-S Gland</th> </tr> </thead> <tbody> <tr> <td>I, IIC, IIB, IIA</td> <td>YES</td> <td>Any</td> <td>Zone 1 or 2</td> <td>YES</td> </tr> </tbody> </table> <b>Other Equipment</b> Mining Equipment Group I, M2 Ignitable Dust, Zones 21 and 22					Gas Group	Internal Ignition Source	Enclosure Volume	Which Zone	Use CR-S Gland	I, IIC, IIB, IIA	YES	Any	Zone 1 or 2	YES
Gas Group	Internal Ignition Source	Enclosure Volume	Which Zone	Use CR-S Gland											
I, IIC, IIB, IIA	YES	Any	Zone 1 or 2	YES											
INGRESS PROTECTION	IP66 & IP68 @ 100 metres, Enclosure Type 4X Meets the requirements of DTS01 1991														
CURING TIME	@ 21°C Conductor termination can be effected after 1 hour The equipment can be energised after 4 hours The compound chamber can be inspected after 4 hours														
MATERIALS	Brass CZ121 (CR-SB) 316 Stainless Steel (CR-SS)  Inner LSOH compound Entry thread seal: Red LSOH silicone														
OPTIONS	THREADS	ISO Metric; NPT; NPS; ISO Pipe Thread (BSP Taper, BSP Parallel)													
	PLATING	Zinc (ZP); Nickel (NP); Tin (TP); Electroless Nickel (EN)													
OPERATING TEMPERATURES	-60°C to +85°C														
ACCESSORIES	Locknut - Brass (ACBLN); 316 Stainless Steel (ACSLN) Earth Tag - Brass (ACBET), 316 Stainless Steel (ACSET) IP Washer - Nylon (ACNSW); Red Fibre (ACFSW) Serrated Lock Washer - 316 Stainless Steel (ACSSW), Galvanised Steel (ACGSW)														

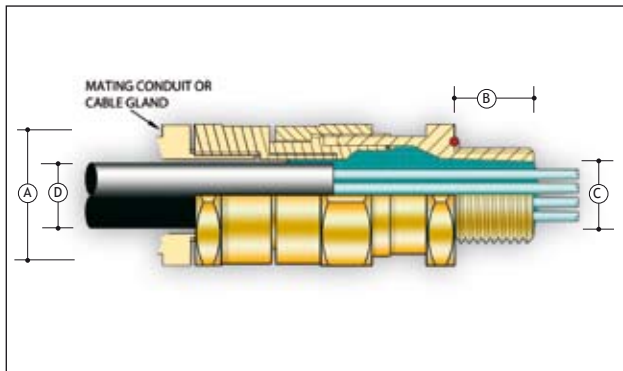

EXAMPLE PART NUMBER	<p>Sample: CR-SB 20 /NP /M20 /M20</p> <p>CR-S:</p> <p>CR-S - Gland type</p> <p>**.*B - Material (Brass)</p> <p>20 - Fitting size = 20</p> <p>NP - Nickel plating</p> <p>M20 - Male entry thread</p> <p>M20 - Female thread for gland or conduit entry</p>
---------------------	---

Fitting Size Ref	Male Entry Threads		Female Entry Threads		Entry Thread Length [B]	Max Across Corners [A]	Max Protrusion Length	Sealing Range Cable Conductors / Cores		
	Metric	NPT	Metric	NPT				Max No. of Cores	Max Over Cores [C]	Max Cable Inside Fitting [D]
20	M20	1/2" or 3/4"	M20	1/2" or 3/4"	16	33.0	57.0	14	12.5	14.0
25	M25	3/4" or 1"	M25	3/4" or 1"	16	41.4	63.0	25	17.8	20.0
32	M32	1" or 1 1/4"	M32	1" or 1 1/4"	16	50.6	67.0	50	23.5	26.3
40	M40	1 1/4" or 1 1/2"	M40	1 1/4" or 1 1/2"	16	60.5	68.0	80	28.8	32.2
50	M50	2"	M50	2"	16	71.5	68.0	100	39.4	44.1
63	M63	2 1/2"	M63	2 1/2"	19	88.0	72.0	120	50.0	56.0
75	M75	3"	M75	3"	19	99.0	78.0	140	60.8	68.0
80	M80 x 2	3" or 3 1/2"	M80 x 2	3" or 3 1/2"	25	115.2	103.0	160	64.4	72.0
85	M85 x 2	3" or 3 1/2"	M85 x 2	3" or 3 1/2"	25	115.2	103.0	180	69.8	78.0
90	M90 x 2	3 1/2" or 4"	M90 x 2	3 1/2" or 4"	25	125.7	104.0	200	75.1	84.0
100	M100 x 2	3 1/2" or 4"	M100 x 2	3 1/2" or 4"	25	125.7	104.0	220	80.5	90.0

All Dimensions are in mm

**NOTES:**

- Please note that dimensions (A) & (B) may differ for glands with non-Metric entry threads. Please refer to our thread data tables for specific dimensions
- Integral entry thread seal option is not available for glands with tapered entry threads. IP washers can be supplied if required
- Unless otherwise stated ISO Metric entry threads have a 1.5mm pitch
- For Flameproof Exd applications the female thread into which the gland is to be fitted must comply with clause 5.3 of EN 50018:2000 (clause 5.3 IEC 79-1) and an engagement of at least 5 full threads must be achieved for parallel threads and should be achieved for tapered threads
- If CR-S type glands are fitted into non-metallic enclosures they must be included within the earth circuit of the system
- The user should seek expert advice if intending to combine flammable gases and combustible dusts in one environment/installation
- To maintain ingress protection a thread sealant should be applied to the conduit thread
- Full assembly instructions are supplied with glands, the instructions must be read prior to installation and adhered to in full
- In order to maintain an IP rating greater than IP54, when used in a clearance hole, a suitable IP washer is required.
- Peppers supplies cable glands with parallel entry threads which conform to the flameproof threaded joint requirements of IEC 60079-1 and other equivalent standards. They usually incorporate a thread run out according to the available machining techniques, and will not have a full-form thread for the entire length. Peppers will not be held responsible for clients' installations where this has not been taken into account.

<http://www.cableglands.com>

# Peppers Cable Glands Limited

Stanhope Road, Camberley, Surrey, GU15 3BT United Kingdom  
 Telephone: +44 (0) 1276 64232  
 Facsimile: +44 (0) 1276 691752  
 Email: sales@peppers.co.uk



## Barrier Gland:- Type UL-C



Including type No's:

U	L	C	*	*
			B	R
			S	

UL-C Type Explosion-proof glands featuring Croclock<sup>®</sup>, provide a compound seal preventing the passage of gas or vapours through the gland and the propagation of flame into the cable core. The glands are UL listed; suitable for Marine Shipboard Jacketed or non-Jacketed cable; NEMA 4X applications and are Deluge-Proof.

DESIGN STANDARD	UL2225 & UL514B	
CERTIFICATION	CLASS I, DIVISION 1 GAS GROUPS ABCD	
CERTIFICATE	File No. E248936	
GLAND MARKING	-25+85C UL-C CL I Div 1 ABCD 4X CL I Zone 1 IIC 34WR Peppers GU15 3BT UK IP66	
LISTED APPLICATION	Class I, Division 1 ABCD Croclock <sup>®</sup> UL-C type glands will maintain the Explosion-Proof integrity of electrical equipment when used with suitable listed cable types. <b>NEC 505:</b> Class I, Zone 1, Gas Groups IIC, IIB, IIA. Croclock <sup>®</sup> UL-C type glands will maintain the Flameproof integrity of electrical equipment when used with suitable listed cable types.	
INGRESS PROTECTION	NEMA 4X. Meets the requirements of DTS01 1991 and IP66	
CURING TIME	@21°C Conductor termination can be effected after 1 hour The equipment can be energised after 4 hours	
MATERIALS	Brass CZ121 (UL-CB) Stainless Steel 316 (UL-CS) Inner LSOH compound Standard outer sheath seal is LSOH silicone, white Reduced bore outer sheath seal is LSOH silicone, red (UL-C*R)	
OPTIONS	THREADS	ISO Metric; NPT; NPSM
	PLATING	Zinc (ZP); Nickel (NP); Tin (TP); Electroless Nickel (EN) - All entry threads are nickel plated as standard
OPERATING TEMPERATURES	-25°C to +85°C	

ACCESSORIES	Locknut - Brass (ACBLN); 316 Stainless Steel (ACSLN) Earth Tag - Brass (ACBET), 316 Stainless Steel (ACSET) IP Washer - Nylon (ACNSW); Red Fibre (ACFSW) Serrated Lock Washer - 316 Stainless Steel (ACSSW), Galvanised Steel (ACGSW) Shroud - PVC (ACSPVC)
-------------	---

EXAMPLE PART NUMBER	Sample: <b>UL-CBR / 20 / 050NPT</b>  UL-C - Gland type, armour type (SWA) and body material (Brass) UL-*B - Material (Brass) UL-**R - Reduced bore outer seal 20 - Fitting size = 20 050NPT - ½” NPT entry thread
---------------------	---

Gland Size	Entry Threads		Entry Thread Length [B] NPT	Max Across Corners [A]	Max Protrusion Length	Gland Seal Range				Armour Acceptance Range	Shroud Size	
						Cable Inner Sheath [C]  Max Inner Sheath	Cable Outer Sheath [D]		Reduced (R)			
	Metric	NPT					Min	Max	Min			Max
16	M20	½” or ¾”	0.783	1.102	2.835	0.461	0.362	0.531	0.264	0.406	0.006-0.049	L24
20s	M20	½” or ¾”	0.783	1.102	2.835	0.461	0.453	0.630	0.370	0.492	0.006-0.049	L24
20	M20	½” or ¾”	0.783	1.299	2.874	0.551	0.610	0.831	0.563	0.693	0.006-0.049	EL30
25	M25	¾” or 1”	0.795	1.630	3.268	0.787	0.799	1.079	0.689	0.941	0.006-0.063	EL38
32	M32	1” or 1¼”	0.985	1.992	4.055	1.035	1.051	1.339	0.984	1.201	0.006-0.079	EL46
40	M40	1¼” or 1½”	1.008	2.382	4.134	1.268	1.299	1.598	1.154	1.425	0.008-0.079	EL55
50s	M50	2”	1.059	2.815	4.528	1.504	1.551	1.839	1.499	1.669	0.008-0.098	EL65
50	M50	2”	1.059	2.815	4.528	1.736	1.799	2.094	1.618	1.909	0.008-0.098	EL65
63s	M63	2½”	1.571	3.465	4.528	1.972	2.051	2.343	1.846	2.157	0.012-0.098	EL80
63	M63	2½”	1.571	3.465	4.528	2.205	2.299	2.591	2.118	2.409	0.012-0.098	EL80
75s	M75	3”	1.634	4.134	4.803	2.441	2.551	2.843	2.469	2.677	0.012-0.098	EL104
75	M75	3”	1.634	4.134	4.803	2.677	2.799	3.071	2.618	2.890	0.012-0.098	EL104

All Dimensions are in inches

**NOTES:**

- Gland Size does not necessarily equate to the entry thread size
- Integral entry thread seal option is not available for glands with tapered entry threads. IP washers can be supplied if required
- Please note that dimensions (A) and (B) may differ for glands with parallel entry threads. Please refer to our thread data tables for specific dimensions
- Unless otherwise stated ISO Metric entry threads have a 1.5mm pitch
- Full assembly instructions are supplied with glands, the instructions must be read prior to installation and adhered to in full
- For Class I Group A locations, the joint made by fitting the gland to the enclosure female thread must comply with standard UL 886 clause 6.1 as follows:-  
 NPT threads must have at least five threads fully engaged  
 Metric and NPS threads must have at least eight threads fully engaged
- In order to maintain an IP rating greater than IP54, when used in a clearance hole, a suitable IP washer is required.
- Peppers supplies cable glands with parallel entry threads which conform to the flameproof threaded joint requirements of IEC 60079-1 and other equivalent standards. They usually incorporate a thread run out according to the available machining techniques, and will not have a full-form thread for the entire length. Peppers will not be held responsible for clients’ installations where this has not been taken into account.

<http://www.cableglands.com>

# Peppers Cable Glands Limited

Stanhope Road, Camberley, Surrey, GU15 3BT United Kingdom  
 Telephone: +44 (0) 1276 64232  
 Facsimile: +44 (0) 1276 691752  
 Email: sales@peppers.co.uk



## Barrier Gland:- Type UL-X



Including type No's:

U	L	X	*
			B
			S

UL-X Type Explosion-proof glands provide a compound seal preventing the passage of gas or vapours through the gland and the propagation of flame into the cable core. The glands are UL listed; suitable for Marine Shipboard non-armoured cable; NEMA 4X applications and are Deluge-Proof.

DESIGN STANDARD	UL2225 & UL514B		
CERTIFICATION		CLASS I, DIVISION 2 GAS GROUPS ABCD	
CERTIFICATE	File No. E248936		
GLAND MARKING	-25+85C UL-X CL I Div 2 ABCD 4X CL I Zone 1 IIC 34WR Peppers GU15 3BT UK IP66		
LISTED APPLICATION	Class I, Division 2 ABCD UL-X type glands will maintain the Explosion-Proof integrity of electrical equipment when used with suitable listed cable types. <b>NEC 505:</b> Class I, Zone 2, Gas Groups IIC, IIB, IIA. UL-X type glands will maintain the Flameproof integrity of electrical equipment when used with suitable listed cable types.		
INGRESS PROTECTION	NEMA 4X. Meets the requirements of DTS01 1991		
CURING TIME	@21°C Conductor termination can be effected after 1 hour The equipment can be energised after 4 hours		
MATERIALS	Brass CZ121 (UL-XB) Stainless Steel 316 (UL-XS) Inner LSOH compound		
OPTIONS	THREADS	ISO Metric; NPT; NPSM	
	PLATING	Zinc (ZP); Nickel (NP); Tin (TP); Electroless Nickel (EN) - All entry threads are nickel plated as standard	
OPERATING TEMPERATURES	-25°C to +85°C		

<b>ACCESSORIES</b>	Locknut - Brass (ACBLN); 316 Stainless Steel (ACSLN) Earth Tag - Brass (ACBET), 316 Stainless Steel (ACSET) IP Washer - Nylon (ACNSW); Red Fibre (ACFSW) Serrated Lock Washer - 316 Stainless Steel (ACSSW), Galvanised Steel (ACGSW) Shroud - PVC (ACSPVC)
<b>EXAMPLE PART NUMBER</b>	Sample: <b>UL-XB / 20 / 050NPT</b>  UL-X - Gland type UL-*B - Material (Brass) 20 - Fitting size = 20 050NPT - ½" NPT entry thread

Gland Size	Trade Size		Entry Thread Length	Max Across Corners	Max Protrusion Length	Maximum Sheath Diameter [C]	Shroud Size
	Metric	NPT	[B] NPT	[A]			
20s	M20	½" or ¾"	0.783	1.102	1.654	0.461	L24
20	M20	½" or ¾"	0.783	1.299	1.732	0.551	L30
25	M25	¾" or 1"	0.795	1.630	1.890	0.787	L38
32	M32	1" or 1¼"	0.985	1.992	2.087	1.035	L46
40	M40	1¼" or 1½"	1.008	2.382	2.126	1.268	L55
50	M50	2"	1.059	2.815	2.126	1.736	L65
63	M63	2½"	1.571	3.465	2.165	2.205	L80
75	M75	3"	1.634	4.134	2.362	2.677	L90

All Dimensions are in inches

**NOTES:**

- Gland Size does not necessarily equate to the entry thread size
- Integral entry thread seal option is not available for glands with tapered entry threads. IP washers can be supplied if required
- Please note that dimensions (A) and (B) may differ for glands with parallel entry threads. Please refer to our thread data tables for specific dimensions
- Unless otherwise stated ISO Metric entry threads have a 1.5mm pitch
- Full assembly instructions are supplied with glands, the instructions must be read prior to installation and adhered to in full
- For Class I Group A locations, the joint made by fitting the gland to the enclosure female thread must comply with standard UL 886 clause 6.4.1 as follows:-
  - NPT threads must have at least five threads fully engaged
  - Metric and NPS threads must have at least eight threads fully engaged
- In order to maintain an IP rating greater than IP54, when used in a clearance hole, a suitable IP washer is required.
- Peppers supplies cable glands with parallel entry threads which conform to the flameproof threaded joint requirements of IEC 60079-1 and other equivalent standards. They usually incorporate a thread run out according to the available machining techniques, and will not have a full-form thread for the entire length. Peppers will not be held responsible for clients' installations where this has not been taken into account.

<http://www.cableglands.com>

## Peppers Cable Glands Limited

Stanhope Road, Camberley, Surrey, GU15 3BT United Kingdom  
 Telephone: +44 (0) 1276 64232  
 Facsimile: +44 (0) 1276 691752  
 Email: sales@peppers.co.uk



### Barrier Gland:- Type UL-U



Including type No's:

U	L	U	*
			B
			S

UL-U Type Explosion-proof glands featuring provide a compound seal preventing the passage of gas or vapours through the gland and the propagation of flame into the cable core. The glands are UL listed; suitable for Marine Shipboard non-armoured cable; NEMA 4X applications and are Deluge-Proof.

DESIGN STANDARD	UL2225 & UL514B		
CERTIFICATION	CLASS I, DIVISION 2 GAS GROUPS ABCD		
CERTIFICATE	File No. E248936		
GLAND MARKING	-25+85C UL-U CL I Div 2 ABCD 4X CL I Zone 1 IIC 34WR Peppers GU15 3BT UK IP66		
LISTED APPLICATION	Class I, Division 2 ABCD UL-U type glands will maintain the Explosion-Proof integrity of electrical equipment when used with suitable listed cable types. <b>NEC 505:</b> Class I, Zone 2, Gas Groups IIC, IIB, IIA. UL-U type glands will maintain the Flameproof integrity of electrical equipment when used with suitable listed cable types.		
INGRESS PROTECTION	NEMA 4X. Meets the requirements of DTS01 1991		
CURING TIME	@21°C Conductor termination can be effected after 1 hour The equipment can be energised after 4 hours		
MATERIALS	Brass CZ121 (UL-UB) Stainless Steel 316 (UL-US) Inner LSOH compound Standard outer sheath seal is LSOH silicone, white		
OPTIONS	THREADS	ISO Metric; NPT; NPSM	
	PLATING	Zinc (ZP); Nickel (NP); Tin (TP); Electroless Nickel (EN) - All entry threads are nickel plated as standard	
OPERATING TEMPERATURES	-25°C to +85°C		

ACCESSORIES	Locknut - Brass (ACBLN); 316 Stainless Steel (ACSLN) Earth Tag - Brass (ACBET), 316 Stainless Steel (ACSET) IP Washer - Nylon (ACNSW); Red Fibre (ACFSW) Serrated Lock Washer - 316 Stainless Steel (ACSSW), Galvanised Steel (ACGSW) Shroud - PVC (ACSPVC)
-------------	---

EXAMPLE PART NUMBER	Sample: <b>UL-UB / 20 / 050NPT</b>  UL-U - Gland type UL-*B - Material (Brass) 20 - Fitting size = 20 050NPT - ½" NPT entry thread
---------------------	---

Gland Size	Entry Threads		Entry Thread Length [B] NPT	Max Across Corners [A]	Max Protrusion Length	Gland Seal Range			Shroud Size
	Metric	NPT				Cable Inner Sheath [C]	Cable Outer Sheath [D]		
						Max Inner Sheath	Min	Max	
16	M20	½" or ¾"	0.783	1.102	2.835	0.461	0.134	0.331	L24
20s	M20	½" or ¾"	0.783	1.102	2.835	0.461	0.189	0.461	L24
20	M20	½" or ¾"	0.783	1.299	2.874	0.551	0.374	0.551	EL30
25	M25	¾" or 1"	0.795	1.630	3.268	0.787	0.461	0.787	EL38
32	M32	1" or 1¼"	0.985	1.992	4.055	1.035	0.713	1.035	EL46
40	M40	1¼" or 1½"	1.008	2.382	4.134	1.268	0.890	1.268	EL55
50s	M50	2"	1.059	2.815	4.528	1.504	1.110	1.504	EL65
50	M50	2"	1.059	2.815	4.528	1.736	1.303	1.736	EL65
63s	M63	2½"	1.571	3.465	4.528	1.972	1.547	1.972	EL80
63	M63	2½"	1.571	3.465	4.528	2.205	1.839	2.205	EL80
75s	M75	3"	1.634	4.134	4.803	2.441	2.059	2.441	EL104
75	M75	3"	1.634	4.134	4.803	2.677	2.283	2.677	EL104

All Dimensions are in inches

**NOTES:**

- Gland Size does not necessarily equate to the entry thread size
- Integral entry thread seal option is not available for glands with tapered entry threads. IP washers can be supplied if required
- Please note that dimensions (A) and (B) may differ for glands with parallel entry threads. Please refer to our thread data tables for specific dimensions
- Unless otherwise stated ISO Metric entry threads have a 1.5mm pitch
- Full assembly instructions are supplied with glands, the instructions must be read prior to installation and adhered to in full
- For Class I Group A locations, the joint made by fitting the gland to the enclosure female thread must comply with standard UL 886 clause 6.4.1 as follows:-  
 NPT threads must have at least five threads fully engaged  
 Metric and NPS threads must have at least eight threads fully engaged
- In order to maintain an IP rating greater than IP54, when used in a clearance hole, a suitable IP washer is required.
- Peppers supplies cable glands with parallel entry threads which conform to the flameproof threaded joint requirements of IEC 60079-1 and other equivalent standards. They usually incorporate a thread run out according to the available machining techniques, and will not have a full-form thread for the entire length. Peppers will not be held responsible for clients' installations where this has not been taken into account.

<http://www.cableglands.com>

# Peppers Cable Glands Limited

Stanhope Road, Camberley, Surrey, GU15 3BT United Kingdom  
 Telephone: +44 (0) 1276 64232  
 Facsimile: +44 (0) 1276 691752  
 Email: sales@peppers.co.uk



## Cable Gland:- Type BW



BW type glands provide an integral armour clamp for armoured cable. The integral armour clamp provides an electrical bond between the cable armour and the gland. BW type glands maintain IP30.

DESIGN STANDARD	BS 6121:1989		
GLAND MARKING	Example: BS6121 Part 1 BW [size] [thread] PCGL (or PEPPERS)		
INGRESS PROTECTION	IP30		
MATERIALS	Brass CZ121		
VARIATIONS	All variants of the BW type gland feature a separate armour clamping ring to allow for inspection of the clamped armour:- Brass (BWL)  Integral Earth version for HV applications: Brass (BWLIE)		
OPERATING TEMPERATURES	-100°C to +600°C		
OPTIONS	THREADS	ISO Metric only	
	CLAMPS	SWA Clamping using gland body (BW) SWA steel wire armour - clamping ring (BWL) SWB woven steel wire armour or STA steel tape armour - clamping ring (BXL/BZL)	
	PLATING	Zinc (ZP); Nickel (NP); Tin (TP); Electroless Nickel (EN)	
ACCESSORIES	Locknut - Brass (ACBLN); Steel (ACMLN) Earth Tag - Brass (ACBET) Shroud - PVC (ACSPVC)  Gland and accessory kits: K1- includes gland, steel locknut, earhtag and PVC shroud		
EXAMPLE PART NUMBER	Sample: <b>BW K1/ZP/20S/M20</b> <b>BW:</b> BW - Gland type, armour type (SWA) and body material (Brass) K1 - Supplied complete with accessories (PVC Shroud) ZP - Zinc plating 20s - Gland size with regards to cable acceptance range M20 - Entry thread		

Gland Size	Entry Threads	Entry Thread Length	Max Across Corners	Max Protrusion Length	Gland Seal Range				Armour Acceptance Range		Shroud Size
					Cable Inner Sheath [C]		Cable Outer Sheath [D]		W	XZ Clamp Ring Version Only	
	Metric	[B]	[A]	Min	Max	Min	Max				
20s	M20	10	24.2	20.0	-	11.7	-	16.0	0.90-1.25	0.15-0.35	S22
20	M20	10	29.7	20.0	-	14.0	-	21.0	0.90-1.25	0.15-0.50	S27
25	M25	10	45.1	22.0	-	20.0	-	27.4	1.25-1.60	0.15-0.50	S36
32	M32	10	50.6	25.0	-	26.3	-	34.0	1.60-2.00	0.15-0.55	S41
40	M40	15	60.5	30.0	-	32.2	-	40.6	1.60-2.00	0.20-0.60	L55
50	M50	15	71.5	32.0	-	44.1	-	53.2	2.00-2.50	0.20-0.60	L65
63	M63	15	88.0	42.0	-	56.0	-	65.8	2.50	0.30-0.80	L80
75	M75	15	99.0	50.0	-	68.0	-	78.0	2.50	0.30-1.00	L90
80	M80	20	115.2	50.0	-	72.0	-	84.0	3.15	0.45-1.00	S104
85	M85	20	115.2	50.0	-	78.0	-	90.0	3.15	0.45-1.00	S104
90	M90	20	125.7	50.0	-	84.0	-	96.0	3.15	0.45-1.00	S114
100	M100	20	125.7	50.0	-	90.0	-	102.0	-3.15	0.45-1.00	S114

All Dimensions are in Millimetres

**NOTES:**

- Gland Size does not necessarily equate to the entry thread size
- "W" refers to the wire diameter in a steel wire armoured cable
- Unless otherwise stated ISO Metric entry threads have a 1.5mm pitch
- Shroud sizes above are for type BW only
- Full assembly instructions are available upon request, the instructions should be read prior to installation and adhered to in full

<http://www.cableglands.com>

# Peppers Cable Glands Limited

Stanhope Road, Camberley, Surrey, GU15 3BT United Kingdom  
 Telephone: +44 (0) 1276 64232  
 Facsimile: +44 (0) 1276 691752  
 Email: sales@peppers.co.uk



## Cable Gland:- Type CWL



Including type No's:

C	*	*	L	*	*	*
	3	W		S	IE	R
		X		A		
		Z				

CWL type glands provide a seal on the outer sheath and an armour specific armour clamp for armoured cable. The armour clamp provides an electrical bond between the cable armour and the gland. CWL type glands maintain IP66.

DESIGN STANDARD	BS EN 50262: 1999	
GLAND MARKING	Example: CWL [size] [thread] PCGL (or Peppers)	
INGRESS PROTECTION	IP66	
MATERIALS	Brass CZ121 (CWL) 316 Stainless Steel (CWLS) Aluminium (CWLA) Outer sheath seal material: Standard (C) Neoprene, black. Option (C3) Silicone, white. Reduced bore outer sheath seal (R) Silicone, red. (CWLR)	
VARIATIONS	Integral Earth version for HV applications: Brass (CWLIE); 316 Stainless Steel (CWLSIE)	
OPTIONS	THREADS	ISO Metric; NPT; NPS; ISO Pipe Thread (BSP Taper, BSP Parallel); PG
	SEALS	Extended operating temperature -60°C to +180°C, halogen free versions: Brass (C3WL); 316 Stainless Steel (C3WLS)
	CLAMPS	SWA steel wire armour (CWL) SWB woven steel wire armour or STA steel tape armour (CXZL)
	PLATING	Zinc (ZP); Nickel (NP); Tin (TP); Electroless Nickel (EN)
OPERATING TEMPERATURES	Standard Seals -20°C to +85°C Silicone Seals -60°C to +180°C	
ACCESSORIES	Locknut - Brass (ACBLN); 316 Stainless Steel (ACSLN); Aluminium (ACALN) Earth Tag - Brass (ACBET), 316 Stainless Steel (ACSET); Aluminium (ACAET) IP Washer - Nylon (ACNSW); Red Fibre (ACFSW) Serrated Lock Washer - 316 Stainless Steel (ACSSW), Galvanised Steel (ACGSW) Shroud - PVC (ACSPVC); PCP (ACSPCP); Low Smoke Zero Halogen (ACSSIO)  Gland and accessory kits: K1- includes gland, locknut, earthtag and PVC shroud C3WLK1 - includes brass gland, brass locknut, brass earthtag and zero halogen shroud	
EXAMPLE PART NUMBER	Sample: <b>CWL R K1/ZP/20S/M20</b> CWL: CWL - Gland type, seal material, armour type (SWA) and body material (Brass) C3WL - Seal material (Silicone)  R - Reduced bore outer seal K1 - Supplied complete with accessories (PVC Shroud) ZP - Zinc plating 20s - Gland size with regards to cable acceptance range M20 - Entry thread	

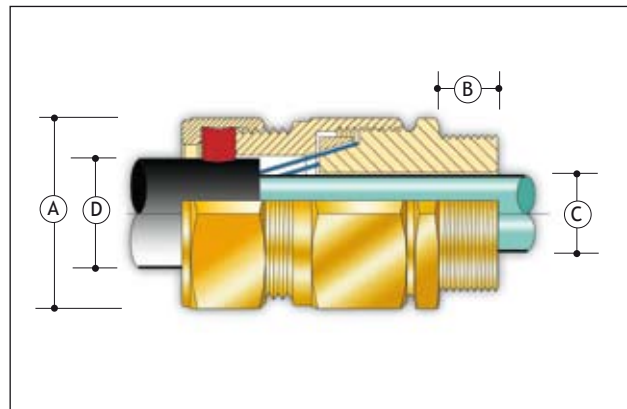

Gland Size	Entry Threads		Entry Thread Length [B]	Max Across Corners [A]	Max Protusion Length	Gland Seal Range						Armour Acceptance Range		Shroud Size
						Cable Inner Sheath [C]		Cable Outer Sheath [D]						
	Metric	NPT/BSP				Standard		Reduced (R)		W	XZ			
						Min	Max	Min	Max			Min	Max	
16	M20	1/2" or 3/4"	16	26.5	54.0	-	8.4	9.0	13.5	6.7	10.3	0.90	0.15-0.35	L24
20s	M20	1/2" or 3/4"	16	26.5	54.0	-	11.7	11.5	16.0	9.4	12.5	0.90-1.25	0.15-0.35	L24
20	M20	1/2" or 3/4"	16	33.0	54.0	-	14.0	15.5	21.0	12.0	17.6	0.90-1.25	0.15-0.50	L30
25	M25	3/4" or 1"	16	41.4	54.0	-	20.0	20.3	27.4	16.8	23.9	1.25-1.60	0.15-0.50	L38
32	M32	1" or 1 1/4"	16	50.6	60.0	-	26.3	26.7	34.0	23.2	30.5	1.60-2.00	0.15-0.55	L46
40	M40	1 1/4" or 1 1/2"	16	60.5	67.0	-	32.2	33.0	40.6	28.6	36.2	1.60-2.00	0.20-0.60	L55
50s	M50	1 1/2" or 2"	16	71.5	67.0	-	38.2	39.4	46.7	34.8	42.4	2.00-2.50	0.20-0.60	L65
50	M50	2"	16	71.5	67.0	-	44.1	45.7	53.2	41.1	48.5	2.00-2.50	0.30-0.60	L65
63s	M63	2" or 2 1/2"	19	88.0	69.0	-	50.1	52.1	59.4	47.5	54.8	2.50	0.30-0.80	L80
63	M63	2 1/2"	19	88.0	69.0	-	56.0	58.4	65.8	53.8	61.2	2.50	0.30-0.80	L80
75s	M75	2 1/2" or 3"	19	99.0	77.0	-	62.0	64.8	72.2	60.2	68.0	2.50	0.30-1.00	L90
75	M75	3"	19	99.0	77.0	-	68.0	71.1	78.0	66.5	73.4	2.50	0.30-1.00	L90
80	M80 x 2	3" or 3 1/2"	25	115.2	104.0	-	72.0	77.0	84.0	-	-	3.15	0.45-1.00	L104
80H	M80 x 2	3" or 3 1/2"	25	115.2	104.0	-	72.0	79.6	90.0	-	-	3.15	0.45-1.00	L104
85	M85 x 2	3" or 3 1/2"	25	115.2	104.0	-	78.0	79.6	90.0	75.0	85.4	3.15	0.45-1.00	L104
90	M90 x 2	3 1/2" or 4"	25	125.7	104.0	-	84.0	88.0	96.0	-	-	3.15	0.45-1.00	L114
90H	M90 x 2	3 1/2" or 4"	25	125.7	104.0	-	84.0	92.0	102.0	-	-	3.15	0.45-1.00	L114
100	M100 x 2	3 1/2" or 4"	25	125.7	104.0	-	90.0	92.0	102.0	87.4	97.4	3.15	0.45-1.00	L114

All Dimensions are in Millimetres

NOTES:

- Gland Size does not necessarily equate to the entry thread size
- "W" refers to the wire diameter in a steel wire armoured cable
- "XZ" refers to the wire diameter in a woven steel wire armoured cable or the tape thickness in a steel tape armoured cable
- Please note that dimensions (A) and (B) may differ for glands with non-Metric entry threads. Please refer to our thread data tables for specific dimensions
- Unless otherwise stated ISO Metric entry threads have a 1.5mm pitch
- Full assembly instructions are available upon request, the instructions should be read prior to installation and adhered to in full
- In order to maintain an IP rating greater than IP54, when used in a clearance hole, a suitable IP washer is required.

<http://www.cableglands.com>

# Peppers Cable Glands Limited

Stanhope Road, Camberley, Surrey, GU15 3BT United Kingdom  
 Telephone: +44 (0) 1276 64232  
 Facsimile: +44 (0) 1276 691752  
 Email: sales@peppers.co.uk



## Cable Gland:- Type E1W



Including type No's:

E	*	*	*	*	*
1	W	S	IE	R	
2	X	A			
3	Z				

E1W type glands provide a seal on the inner sheath, a seal on the outer sheath and an armour specific armour clamp for armoured cable. The armour clamp provides an electrical bond between the cable armour and the gland. E1W type glands maintain IP66, IP67.

DESIGN STANDARD	BS EN 50262: 1999	
GLAND MARKING	Example: E1W [size] [thread] PCGL (or Peppers)	
INGRESS PROTECTION	IP66, IP67 and IP68	
MATERIALS	Brass CZ121 (E1W) 316 Stainless Steel (E1WS) Aluminium (E1WA) Inner & outer sheath seal material: Standard (E1) Neoprene, black. Option (E3) Silicone, white. Reduced bore outer sheath seal (R) Silicone, red. (E1WFR)	
VARIATIONS	For lead sheath cables the gland is fitted with a metallic continuity washer: Brass (E2W); 316 Stainless Steel (E2WS)  Integral earth version for HV appliances: Brass (E1WIE); 316 Stainless Steel (E1WIES)  Omission of outer seal: Brass (D1W); 316 Stainless Steel (D1WS)	
OPTIONS	THREADS	ISO Metric; NPT; NPS; ISO Pipe Thread (BSP Taper, BSP Parallel); PG
	SEALS	Extended operating temperature -60°C to +180°C, halogen free versions: Brass (E3W); 316 Stainless Steel (E3WS)
	CLAMPS	SWA steel wire armour (E1W) SWB woven steel wire armour (E1X) STA steel tape armour (E1Z)
	PLATING	Zinc (ZP); Nickel (NP); Tin (TP); Electroless Nickel (EN)
OPERATING TEMPERATURES	Standard Seals -20°C to +85°C Silicone Seals -60°C to +200°C	
ACCESSORIES	Locknut - Brass (ACBLN); 316 Stainless Steel (ACSLN); Aluminium (ACALN) Earth Tag - Brass (ACBET), 316 Stainless Steel (ACSET); Aluminium (ACAET) IP Washer - Nylon (ACNSW); Red Fibre (ACFSW) Serrated Lock Washer - 316 Stainless Steel (ACSSW), Galvanised Steel (ACGSW) Shroud - PVC (ACSPVC); PCP (ACSPCP); Low Smoke Zero Halogen (ACSSIO)  Gland and accessory kits: K1 - includes gland, locknut, earthtag and PVC shroud E3WK1 - includes brass gland, brass locknut, brass earthtag and zero halogen shroud	

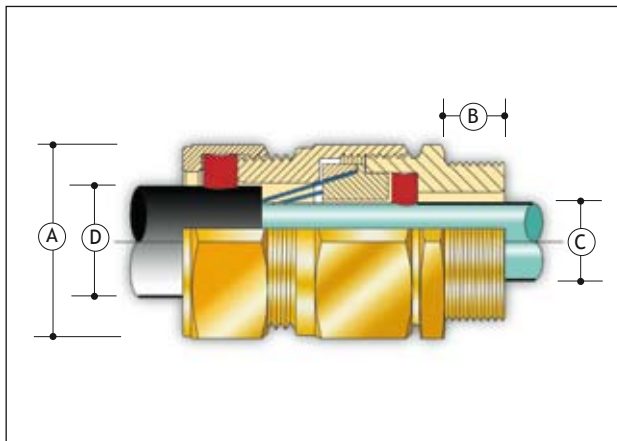

EXAMPLE PART NUMBER	<p>Sample: E1W R K1/ZP/20S/M20</p> <p><b>E1W:</b>  E*W - Gland type, armour type (SWA) and body material (Brass)  *1* - Seal material (Neoprene)</p> <p><b>R</b> - Reduced bore outer seal  <b>K1</b> - Supplied complete with locknut, earth tag and PVC shroud  <b>ZP</b> - Zinc plating  <b>20s</b> - Gland size with regards to cable acceptance range  <b>M20</b> - Entry thread</p>
---------------------	---

Gland Size	Entry Threads		Entry Thread Length [B]	Max Across Corners [A]	Max Protrusion Length	Gland Seal Range						Armour Acceptance Range		Shroud Size
						Cable Inner Sheath [C]		Cable Outer Sheath [D]						
	Standard							Reduced (R)		W	XZ			
	Min	Max				Min	Max	Min	Max					
16	M20	1/2" or 3/4"	16	26.5	58.0	4.0	8.4	8.4	13.5	4.9	10.0	0.90	0.15-0.35	L24
20s	M20	1/2" or 3/4"	16	26.5	58.0	8.0	11.7	11.5	16.0	9.4	12.5	0.90-1.25	0.15-0.35	L24
20	M20	1/2" or 3/4"	16	33.0	58.0	6.7	14.0	15.5	21.0	12.0	17.6	0.90-1.25	0.15-0.50	L30
25	M25	3/4" or 1"	16	41.4	58.0	13.0	20.0	20.3	27.4	16.8	23.9	1.25-1.60	0.15-0.50	L38
32	M32	1" or 1 1/4"	16	50.6	65.0	19.0	26.3	26.7	34.0	23.2	30.5	1.60-2.00	0.15-0.55	L46
40	M40	1 1/4" or 1 1/2"	16	60.5	72.0	25.0	32.2	33.0	40.6	28.6	36.2	1.60-2.00	0.20-0.60	L55
50s	M50	1 1/2" or 2"	16	71.5	73.0	31.5	38.2	39.4	46.7	34.8	42.4	2.00-2.50	0.20-0.60	L65
50	M50	2"	16	71.5	73.0	36.5	44.1	45.7	53.2	41.1	48.5	2.00-2.50	0.30-0.80	L65
63s	M63	2" or 2 1/2"	19	88.0	76.0	42.5	50.1	52.1	59.4	47.5	54.8	2.50	0.30-0.80	L80
63	M63	2 1/2"	19	88.0	76.0	49.5	56.0	58.4	65.8	53.8	61.2	2.50	0.30-0.80	L80
75s	M75	2 1/2" or 3"	19	99.0	82.0	54.5	62.0	64.8	72.2	60.2	68.0	2.50	0.30-1.00	L90
75	M75	3"	19	99.0	82.0	60.5	68.0	71.1	78.0	66.5	73.4	2.50	0.30-1.00	L90
80	M80 x 2	3" or 3 1/2"	25	115.2	110.0	62.2	72.0	77.0	84.0	-	-	3.15	0.45-1.00	L104
80H	M80 x 2	3" or 3 1/2"	25	115.2	110.0	62.2	72.0	79.6	90.0	-	-	3.15	0.45-1.00	L104
85	M85 x 2	3" or 3 1/2"	25	115.2	110.0	69.0	78.0	79.6	90.0	75.0	85.4	3.15	0.45-1.00	L104
90	M90 x 2	3 1/2" or 4"	25	125.7	110.0	74.0	84.0	88.0	96.0	-	-	3.15	0.45-1.00	L114
90H	M90 x 2	3 1/2" or 4"	25	125.7	110.0	74.0	84.0	92.0	102.0	-	-	3.15	0.45-1.00	L114
100	M100 x 2	3 1/2" or 4"	25	125.7	110.0	82.0	90.0	92.0	102.0	87.4	97.4	3.15	0.45-1.00	L114

All Dimensions are in Millimetres

**NOTES:**

- Gland Size does not necessarily equate to the entry thread size
- "W" refers to the wire diameter in a steel wire armoured cable
- "XZ" refers to the wire diameter in a woven steel wire armoured cable or the tape thickness in a steel tape armoured cable
- E3\* gland size 20, the silicone inner seal only seals to a minimum of 11.0mm and NOT 6.7mm
- Please note that dimensions (A) and (B) may differ for glands with non-Metric entry threads. Please refer to our thread data tables for specific dimensions
- Unless otherwise stated ISO Metric entry threads have a 1.5mm pitch
- Full assembly instructions are available upon requests, the instructions should be read prior to installation and adhered to in full
- In order to maintain an IP rating greater than IP54, when used in a clearance hole, a suitable IP washer is required.

<http://www.cableglands.com>

# Peppers Cable Glands Limited

Stanhope Road, Camberley, Surrey, GU15 3BT United Kingdom  
 Telephone: +44 (0) 1276 64232  
 Facsimile: +44 (0) 1276 691752  
 Email: sales@peppers.co.uk



## Cable Gland:- Type A2L



Including type No's:

A	*	L	*
	2		S
	3		A
	4		

A2L type glands provide a single pull resistant seal on the outer sheath of unarmoured cable. A2L type glands maintain IP66, IP68 to 25 metres.

<b>DESIGN STANDARD</b>	BS EN 50262: 1999		
<b>GLAND MARKING</b>	Example: A2L [size] [thread] PCGL (or Peppers)		
<b>INGRESS PROTECTION</b>	IP66 and IP68 @ 25 metres		
<b>MATERIALS</b>	Brass CZ121 (A2L) 316 Stainless Steel (A2LS) Aluminium Alloy (A2LA)  Outer sheath seal material: Standard (A2L) Neoprene, black. Option (A3L) Silicone, white.		
<b>VARIATIONS</b>	For lead sheath cables the gland is fitted with a metallic continuity washer: Brass (A4L); 316 Stainless Steel (A4LS)		
<b>OPTIONS</b>	<b>THREADS</b>	ISO Metric; NPT; NPS; ISO Pipe Thread (BSP Taper, BSP Parallel); PG	
	<b>SEALS</b>	Extended operating temperature -60°C to +180°C, halogen free versions: Brass (A3L); 316 Stainless Steel (A3LS)	
	<b>PLATING</b>	Zinc (ZP); Nickel (NP); Tin (TP); Electroless Nickel (EN)	
<b>OPERATING TEMPERATURES</b>	Standard Seals -20°C to +85°C Silicone Seals - 60°C to +200°C		
<b>ACCESSORIES</b>	Locknut - Brass (ACBLN); 316 Stainless Steel (ACSLN); Aluminium (ACALN) Earth Tag - Brass (ACBET), 316 Stainless Steel (ACSET); Aluminium (ACAET) IP Washer - Nylon (ACNSW); Red Fibre (ACFSW) Serrated Lock Washer - 316 Stainless Steel (ACSSW), Galvanised Steel (ACGSW) Shroud - PVC (ACSPVC); PCP (ACSPCP); Low Smoke Zero Halogen (ACSSIO)  Gland and accessory kits: K1 - includes gland, locknut and PVC shroud		
<b>EXAMPLE PART NUMBER</b>	Sample: A2L K1/ZP/20S/M20 <b>A2L:</b> A*L - Gland type and body material (Brass) *2* - Seal material (Neoprene) K1 - Supplied complete with accessories (PVC Shroud) ZP - Zinc plating 20s - Gland size with regards to cable acceptance range M20 - Entry thread		

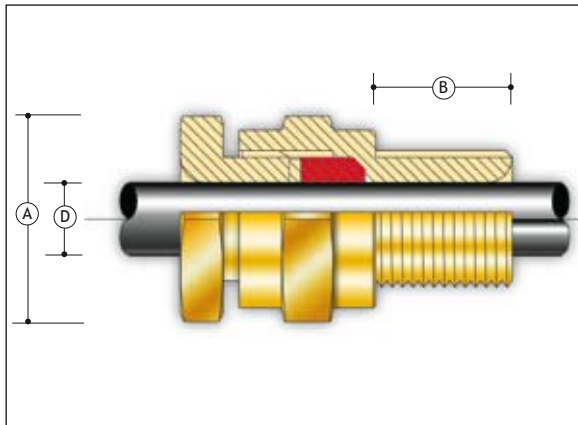

Gland Size	Entry Threads		Entry Thread Length [B]	Max Across Corners [A]	Max Protrusion Length	Gland Seal Range Cable Outer/Lead Sheath [D]		Shroud Size
	Metric	NPT/BSP				Min	Max	
20s	M20	1/2" or 3/4"	116	28.0	33.0	7.2	11.7	L24
20	M20	1/2" or 3/4"	16	33.0	33.0	9.6	14.0	L30
25	M25	3/4" or 1"	16	41.4	33.0	13.5	20.0	L38
32	M32	1" or 1 1/4"	16	50.6	33.0	19.5	26.3	L46
40	M40	1 1/4" or 1 1/2"	16	60.5	37.0	23.0	32.2	L55
50s	M50	1 1/2" or 2"	16	71.5	37.0	28.2	38.2	L65
50	M50	2"	16	71.5	37.0	33.2	44.1	L65
63s	M63	2" or 2 1/2"	19	88.0	37.0	39.3	50.1	L80
63	M63	2 1/2"	19	88.0	37.0	46.7	56.0	L80
75s	M75	2 1/2" or 3"	19	99.0	37.0	52.3	62.0	L90
75	M75	3"	19	99.0	37.0	58.1	68.0	L90
80	M80 x 2	3" or 3 1/2"	25	115.2	50.0	62.3	72.0	L104
85	M85 x 2	3" or 3 1/2"	25	115.2	50.0	69.1	78.0	L104
90	M90 x 2	3 1/2" or 4"	25	125.7	50.0	74.1	84.0	L114
100	M100 x 2	3 1/2" or 4"	25	125.7	50.0	82.0	90.0	L114
110	M110 x 2	-	25	147.0	80.8	87.0	97.0	-
120	M120 x 2	-	25	147.0	80.8	96.0	107.0	-

All Dimensions are in Millimetres

**NOTES:**

- Gland Size does not necessarily equate to the entry thread size
- Please note that dimensions (A) and (B) may differ for glands with non-Metric entry threads. Please refer to our thread data tables for specific dimensions
- Unless otherwise stated ISO Metric entry threads have a 1.5mm pitch
- Full assembly instructions are available upon request, the instructions should be read prior to installation and adhered to in full
- In order to maintain an IP rating greater than IP54, when used in a clearance hole, a suitable IP washer is required.

<http://www.cableglands.com>

# Peppers Cable Glands Limited

Stanhope Road, Camberley, Surrey, GU15 3BT United Kingdom  
 Telephone: +44 (0) 1276 64232  
 Facsimile: +44 (0) 1276 691752  
 Email: sales@peppers.co.uk



## Accessories:- Adaptors and Reducers - Type AR



Including type No's:

A	R	*
		B
		S
		A

AR Series Dual Certified Adaptors and Reducers provide a method of matching electrical thread forms on Ex equipment while maintaining Flameproof Exd and Increased Safety Exe methods of explosion protection and IP66, 68 for IEC type applications. Class I, Division 1 and NEMA 4X, 6P for NEC/CEC type applications.

<b>CERTIFICATION</b>	<p><b>CENELEC</b>                  SIRA00ATEX1094 (Metric Female)                  SIRA99ATEX1115U (Non-Metric Female)                  I M2 II 2DG E Ex de landIIC                  II 2DG E Ex de IIC (Aluminium)</p> <p><b>CSA / A Ex</b>                  Class I, Zone 1, Ex de landIIC                  Class I, Division 1and2 ABCD                  Class II EFG, Class III</p> <p><b>GOST R-Exde IICU</b>                  POCC GB MТ14.B00030</p> <p>IECEX Ex d IIC / Ex e II / Ex d I                  IECEX SIR 05.0042U</p>	
<b>INGRESS PROTECTION</b>	IP66 68, CSA Enclosure Type (NEMA) 4X 6P	
<b>IMPACT RESISTANCE</b>	20Nm (7Nm Aluminium)	
<b>OPERATING TEMPERATURES</b>	Nitrile 'O' Ring -30°C to +100°C Silicone 'O' Ring -50°C to +180°C	
<b>MATERIALS</b>	Brass CZ121 (ARB) 316 Stainless Steel (ARS) Aluminium Alloy (ARA)	
<b>THREADS</b>	ISO Metric; ET; NPT; NPS; ISO Pipe Thread (BSP Taper, BSP Parallel); PG	
<b>SEALS</b>	The standard 'O' Ring material is Nitrile Tapered male thread options are not normally supplied c/w 'O' ring seal, thread sealant should be used to maintain the desired level of ingress protection	
<b>PLATING</b>	Zinc (ZP); Nickel (NP); Tin (TP); Electroless Nickel (EN)	
<b>EXAMPLE PART NUMBER</b>	<p>Sample: <b>ARB/NP/M20/050NPT</b>                  AR - Adapter/Reducer type</p> <p><b>B</b> - Body material (Brass)  <b>NP</b> - Nickel plating  <b>M20</b> - Male thread size  <b>050NPT</b> - Female thread size (1/2" NPT)</p>	

AVAILABLE THREAD SIZES AND CORRESPONDING BORE SIZE									
Metric	Bore	NPT	Bore	ISO Pipe	Bore	ET	Bore	PG	Bore
M16	10.0							7	8.0
M20	14.0	1/2"	15.0	1/2"	15.0	3/4"	14.0	9	10.0
M25	18.0	3/4"	19.0	3/4"	19.0	1"	18.0	11	13.5
M32	24.0	1"	25.0	1"	25.0	1 1/4"	24.0	13.5	14.0
M40	32.0	1 1/4"	32.0	1 1/4"	32.0	1 1/2"	32.0	16	16.0
M50	41.0	1 1/2"	38.0	1 1/2"	38.0	2"	41.0	21	21.0
M63	53.0	2"	49.0	2"	49.0	2 1/2"	53.0	29	29.0
M75	64.0	2 1/2"	60.0	2 1/2"	60.0	3"	64.0	36	38.0
M80 x 2.0	69.0	3"	75.0	3"	75.0			42	45.0
M85 x 2.0	73.0	3 1/2"	88.0	3 1/2"	88.0			48	50.0
M90 x 2.0	78.0	4"	100.0	4"	100.0				
M100 x 2.0	88.0								

All Dimensions are in Millimetres

**NOTES:**

- Full installation instructions are supplied with adaptors and reducers, the instructions must be read prior to installation and adhered to in full
- Unless otherwise stated ISO Metric entry threads have a 1.5mm pitch
- For Flameproof Exd applications the female thread into which the adaptor or reducer is to be fitted must comply with clause 5.3 of EN 50018:2000 (clause 5.3 IEC 79-1)
- For NEC/CEC Explosion Proof applications an engagement of at least 8 full threads must be achieved for parallel threads and 5 full threads must be achieved for tapered threads
- Where AR adaptors and reducers are fitted into non-metallic Increased Safety Exe enclosures they must be included within the earth circuit of the system
- 316 Stainless Steel versions do not feature a marking band. This reduces the overall length of reducers by 5mm, it does not affect the overall length of Adaptors
- Adaptors are used where the thread size of the cable gland or connection device is larger than, or of an equivalent size to the entry thread of the enclosure
- Reducers are used to reduce the entry thread of an enclosure to accept a cable gland or connection device with a smaller thread
- When ordering one needs to specify if IECEx or ATEX certification is required. ATEX versions are supplied as standard.

<http://www.cableglands.com>

# Peppers Cable Glands Limited

Stanhope Road, Camberley, Surrey, GU15 3BT United Kingdom  
 Telephone: +44 (0) 1276 64232  
 Facsimile: +44 (0) 1276 691752  
 Email: sales@peppers.co.uk



## Accessories:- Nylon Adaptors and Reducers - Type ARN



ARN Series Certified Adaptors and Reducers provide a method of matching electrical threadforms on Ex equipment while maintaining Increased Safety Exe methods of explosion protection and IP66, 68 for IEC type applications.

**Adaptors** are used where the thread size of the cable gland or connection device is larger than, or of an equivalent size to the entry thread of the enclosure.

**Reducers** are used to reduce the entry thread of an enclosure to accept a cable gland or connection device with a smaller thread.

CERTIFICATION	<b>CENELEC</b> SIRA00ATEX3091 (Metric Female) SIRA99ATEX3116U (Non-Metric Female) II 2DG E Ex e II  <b>CSA / A Ex</b> Class I, Zone 1, Ex e II Class I, Division 2 ABCD Class II EFG, Class III	
INGRESS PROTECTION	IP66 68, CSA Enclosure Type (NEMA) 4X 6P	
IMPACT RESISTANCE	7Nm	
OPERATING TEMPERATURES	Nitrile 'O' Ring -30°C to +100°C Silicone 'O' Ring -50°C to +125°C	
MATERIALS	30% Glass Filled Nylon (ARN)	
THREADS	ISO Metric; ET; NPT; NPS; ISO Pipe Thread (BSP Taper, BSP Parallel); PG	
SEALS	The standard 'O' Ring material is Nitrile	
EXAMPLE PART NUMBER	Sample: <b>ARN/M20/M25</b> <b>ARN</b> - Body material (Nylon) <b>M20</b> - Male thread size <b>M25</b> - Female thread size	

### AVAILABLE THREAD SIZES AND CORRESPONDING BORE SIZE

Metric	Bore	NPT	Bore	ISO Pipe	Bore	ET	Bore	PG	Bore
M16	9.3							9	9.0
M20	11.0	1/2"	12.0	1/2"	12.0	3/4"	11.0	11	10.0
M25	16.0	3/4"	13.0	3/4"	13.0	1"	16.0	13.5	11.5
M32	21.0	1"	18.0	1"	18.0	1 1/4"	21.0	16	13.5
M40	31.0	1 1/4"	33.0	1 1/4"	33.0	1 1/2"	31.0	21	19.0
M50	40.0	1 1/2"	38.0	1 1/2"	38.0	2"	40.0	29	28.0
								36	37.0
								42	44.0

All Dimensions are in Millimetres

#### NOTES:

- Full installation instructions are supplied with adaptors and reducers, the instructions must be read prior to installation and adhered to in full
- Unless otherwise stated ISO Metric entry threads have a 1.5mm pitch
- Adaptors are used where the thread size of the cable gland or connection device is larger than, or of an equivalent size to the entry thread of the enclosure
- Reducers are used to reduce the entry thread of an enclosure to accept a cable gland or connection device with a smaller thread



whatever the hazard

## Peppers Cable Glands Limited

Stanhope Road, Camberley, Surrey, GU15 3BT United Kingdom  
 Telephone: +44 (0) 1276 64232  
 Facsimile: +44 (0) 1276 691752  
 Email: sales@peppers.co.uk



### Accessories:- Insulating Adaptors - Type IA



IA series Insulated Adaptors provide a method of insulating the cable gland or connection device from the equipment into which it has been installed. IA series Insulated Adaptors maintain Flameproof Exd method of explosion protection and IP66, 68 for IEC type applications. Class I, Division 2 and NEMA 3, 6P for NEC/CEC type applications.

<b>CERTIFICATION</b>	<p><b>CENELEC</b>                  SIRA00ATEX1098 (Metric Female)                  SIRA99ATEX1117U (Non-Metric Female)                  II 2DG E Ex d IIC</p> <p><b>CSA / A Ex</b>                  Class I, Zone 1, Ex d IIC                  Class I, Division 2 ABCD                  Class II EFG, Class III</p> <p><b>GOST R-Exde IIC</b>                  POCC GB M14.B00030</p>	
<b>APPLICATIONS</b>	<p>To avoid relying on the contact between cable termination and equipment enclosure for grounding the cable armour, an insulated adaptor can be fitted to both ends of the cable with a grounding device (i.e. earth tag/lug) fitted between the adaptor and the termination. The armour current can then be taken from the grounding device to ground in a controlled, positive manner that can be inspected easily.</p> <p><b>Single Point Grounding:-</b></p> <ul style="list-style-type: none"> <li>- In many applications it is sufficient to ground the cable armour at one end. For single point grounding the insulated adaptors would again be used at both ends of the cable but with the earth tag fitted only to the end where grounding is required.</li> </ul> <p><b>Single Point Grounding can:-</b></p> <ul style="list-style-type: none"> <li>- reduce the circulating currents that can cause heating of high capacity cables.</li> <li>- reduce the risk of damage to electronic equipment within the enclosure in the event of a short circuit to ground through the enclosure.</li> <li>- reduce the problems of electrical noise on the armour affecting the clean earth required for some sensitive instruments.</li> </ul> <p><b>Electrical properties of insulating material</b></p> <ul style="list-style-type: none"> <li>- Dielectric strength: 90KV/mm</li> <li>- Volume resistivity: <math>8.6 \times 10^{14} \text{ } \Omega/\text{cm}</math></li> <li>- Minimum thickness of insulator: 5mm +/- 1mm</li> <li>- 2KV 'Wet Withstand' Tested</li> </ul>	
<b>INGRESS PROTECTION</b>	IP54, CSA Enclosure Type (NEMA) 3 IP66 68 can be maintained with the use of either IP washers or a non-hardening thread sealant	
<b>IMPACT RESISTANCE</b>	7Nm	
<b>OPERATING TEMPERATURES</b>	-20°C to +60°C	
<b>MATERIALS</b>	Brass CZ121 (IA) 316 Stainless Steel (IAS) Aluminium Alloy (IAA)	
<b>THREADS</b>	ISO Metric; NPT; NPS; ISO Pipe Thread (BSP Taper, BSP Parallel); PG	
<b>PLATING</b>	Zinc (ZP); Nickel (NP); Tin (TP); Electroless Nickel (EN)	

EXAMPLE PART NUMBER	<p>Sample: IA/NP/M20/050NPT</p> <p>IA - Body material (Brass)  NP - Nickel plating  M20 - Male thread size  050NPT - Female thread size (1/2" NPT)</p>
---------------------	--

DIMENSIONAL INFORMATION FOR METRIC TO METRIC VERSIONS						
Metric	Hex A/F	Hex A/C	Total Length	Male Length	Female Depth	Bore
M20	30.5	35.5	54.0	16.0	17.0	13.5
M25	37.6	43.2	54.0	16.0	17.0	19.0
M32	47.2	54.3	54.0	16.0	17.0	25.0
M40	55.9	64.1	54.0	16.0	17.0	30.0
M50	70.1	80.8	54.0	16.0	17.0	40.5
M63	80.0	92.0	54.0	16.0	17.0	53.0
M75	95.3	109.5	54.0	16.0	17.0	65.0
M80 x 2.0	100.0	114.0	63.0	20.0	22.0	70.0
M85 x 2.0	106.4	114.0	63.0	20.0	22.0	75.0
M90 x 2.0	106.4	114.0	63.0	20.0	22.0	80.0

All Dimensions are in Millimetres

**NOTES:**

- Full installation instructions are supplied with insulated adaptors, the instructions must be read prior to installation and adhered to in full
- Unless otherwise stated ISO Metric entry threads have a 1.5mm pitch
- For Flameproof Exd applications the female thread into which the adaptor is to be fitted must comply with clause 5.3 of EN 50018:2000 (clause 5.3 IEC 79-1)

<http://www.cableglands.com>

# Peppers Cable Glands Limited

Stanhope Road, Camberley, Surrey, GU15 3BT United Kingdom  
 Telephone: +44 (0) 1276 64232  
 Facsimile: +44 (0) 1276 691752  
 Email: sales@peppers.co.uk



## Accessories:- Stopping Plugs - Type SPMH



Including type No's:

S	P	M	H	*
				S
				A

SPMH Series Dual Certified Metallic Dome Head Stopping Plugs provide a method of filling unused entries in Ex equipment while maintaining Flameproof Exd and Increased Safety Exe methods of explosion protection and IP66, 68 for IEC type applications. Class I, Division 2 and NEMA 4X, 6P for NEC/CEC type applications.

CERTIFICATION	<p><b>CENELEC</b>                  SIRAO0ATEX1094 I M2 II 2DG E Ex de IandIIC                  SIRAO0ATEX1094 II 2DG E Ex de IIC (Aluminium)</p> <p><b>CSA / A Ex</b>                  Class I, Zone 1, Ex de IandIIC                  Class I, Division 1and2 ABCD                  Class II EFG, Class III</p> <p><b>GOST R-Exde IIC</b>                  POCC GB MП14.B00030</p> <p>IECEX Ex d IIC / Ex e II / Ex d I                  IECEX SIR 05.0042U</p>	
INGRESS PROTECTION	IP66 68, CSA Enclosure Type (NEMA) 4X 6P	
IMPACT RESISTANCE	20Nm (7Nm Aluminium)	
OPERATING TEMPERATURES	Nitrile 'O' Ring -30°C to +100°C Silicone 'O' Ring -50°C to +180°C	
MATERIALS	Brass CZ121 (SPMH) 316 Stainless Steel (SPMHS) Aluminium Alloy (SPMHA)	
THREADS	ISO Metric; NPT; NPS; ISO Pipe Thread (BSP Taper, BSP Parallel); PG	
SEALS	The standard 'O' Ring material is Nitrile	
PLATING	Zinc (ZP); Nickel (NP); Tin (TP); Electroless Nickel (EN)	
EXAMPLE PART NUMBER	Sample: <b>SPMH/NP/M20</b> <b>SPMH</b> - Stopping Plug type and body material (Brass) <b>NP</b> - Nickel plating <b>M20</b> - Male thread size	

SIZES AVAILABLE AND DIMENSIONAL REFERENCES							
Metric	Dim Ref	NPT	Dim Ref	ISO Pipe	Dim Ref	PG	Dim Ref
M16	B					7	A
M20	C	1/2"	D	1/2"	D	9	B
M25	C	3/4"	D	3/4"	D	11	C
M32	C	1"	F	1"	D	13.5	C
M40	C	1 1/4"	F	1 1/4"	D	16	C
M50	C	1 1/2"	F	1 1/2"	D	21	C
M63	C	2"	F	2"	D	29	C
M75	C	2 1/2"	G	2 1/2"	D	36	C
M80 x 2.0	E	3"	G	3"	D	42	C
M85 x 2.0	E	3 1/2"	G			48	C
M90 x 2.0	E	4"	G				
M100 x 2.0	E						

DIMENSIONS							
Dimension Reference	A	B	C	D	E	F	G
Head Diameter	Minimum 6.0mm larger than the major thread diameter						
Hex Socket A/F	6.0	8.0	10.0	10.0	10.0	10.0	10.0
Total Length	21.5	21.5	21.5	24.5	25.5	29.0	39.0
Thread Length	16.0	16.0	16.0	19.0	22.0	23.5	33.5

All Dimensions are in Millimetres

**NOTES:**

- SPMH type stopping plugs are designed for use within either clearance holes or parallel threaded entries, for taper threaded entries we would recommend the use of SPA type stopping plugs
- Full installation instructions are supplied with stopping plugs, the instructions must be read prior to installation and adhered to in full
- Unless otherwise stated ISO Metric entry threads have a 1.5mm pitch
- For Flameproof Exd applications the female thread into which the stopping plug is to be fitted must comply with clause 5.3 of EN 50018:2000 (clause 5.3 IEC 79-1)
- For NEC/CEC Explosion Proof applications an engagement of at least 8 full threads must be achieved for parallel threads and 5 full threads must be achieved for tapered threads
- Where metallic stopping plugs are fitted into non-metallic Increased Safety Exe enclosures they must be included within the earth circuit of the system
- When ordering one needs to specify if IECEx or ATEX certification is required. ATEX versions are supplied as standard.

<http://www.cableglands.com>

# Peppers Cable Glands Limited

Stanhope Road, Camberley, Surrey, GU15 3BT United Kingdom  
 Telephone: +44 (0) 1276 64232  
 Facsimile: +44 (0) 1276 691752  
 Email: sales@peppers.co.uk



## Accessories:- Stopping Plugs - Type SPMHN



SPMHN Series Glass Filled Nylon Dome Head Stopping Plugs provide a method of filling unused entries in increased safety equipment, maintaining Increased Safety Exe methods of explosion protection and IP66, 68 for IEC type applications.

<b>CERTIFICATION</b>	<b>CENELEC</b> SIRAA0ATEX3091 II 2DG E Exe II  <b>CSA / A Ex</b> Class I, Zone 1, Ex e II Class I, Division 2 ABCD Class II EFG, Class III	
<b>INGRESS PROTECTION</b>	IP66 68, CSA Enclosure Type (NEMA) 4X 6P	
<b>IMPACT RESISTANCE</b>	7Nm	
<b>OPERATING TEMPERATURES</b>	Nitrile 'O' Ring -30°C to +100°C Silicone 'O' Ring -50°C to +125°C	
<b>MATERIALS</b>	30% Glass Filled Nylon (SPMHN)	
<b>THREADS</b>	ISO Metric; NPT; NPS; ISO Pipe Thread (BSP Taper, BSP Parallel); PG	
<b>SEALS</b>	The standard 'O' Ring material is Nitrile	
<b>EXAMPLE PART NUMBER</b>	Sample: SPMHN/M20 SPMHN - Stopping Plug type and body material (Nylon) M20 - Male thread size	

### SIZES AVAILABLE AND DIMENSIONAL REFERENCES

Metric	Dim Ref	NPT	Dim Ref	PG	Dim Ref
M16	B			7	A
M20	C	1/2"	C	9	B
M25	C	3/4"	C	11	C
M32	C	1"	C	13.5	C
M40	C	1 1/4"	C	16	C
M50	C	1 1/2"	C	21	C
M63	C	2"	C	29	C
M75	C	2 1/2"	C	36	C
				42	C
				48	C

### DIMENSIONS

Dimension Reference	A	B	C
Head Diameter	Minimum 6.0mm larger than the major thread diameter		
Hex Socket A/F	6.0	8.0	10.0
Total Length	21.5	21.5	21.5
Thread Length	16.0	16.0	16.0

All Dimensions are in Millimetres

#### NOTES:

- SPMHN type stopping plugs are designed for use within either clearance holes or parallel threaded entries, for taper threaded entries we would recommend the use of SPA type stopping plugs
- Full installation instructions are supplied, the instructions must be read prior to installation and adhered to in full
- Unless otherwise stated ISO Metric entry threads have a 1.5mm pitch



2010  
Exe I  
07F05  
0020 Exd IIC/Exe II

whatever the hazard

# Peppers Cable Glands Limited

Stanhope Road, Camberley, Surrey, GU15 3BT United Kingdom  
 Telephone: +44 (0) 1276 64232  
 Facsimile: +44 (0) 1276 691752  
 Email: sales@peppers.co.uk



## Accessories:- Stopping Plugs - Type SPA or SPB



Including type No's:

S	P	*	*
		A	B
		B	S
			A

SPA or SPB Series Certified Metallic Stopping Plugs provide a method of filling unused entries in Ex equipment, maintaining Flameproof Exd method of explosion protection and IP54 for IEC type applications. Class I, Division 1 and NEMA 3 for NEC/CEC type applications.

SPA Type - Externally accessible hexagon recess

SPB Type - Internally accessible hexagon recess

CERTIFICATION	<p>CENELEC SIRA99ATEX1113 II 2DG E Ex d IIC</p> <p>CSA / A Ex Class I, Zone 1, Ex d IIC Class I, Division 1 &amp; 2 ABCD Class II EFG, Class III</p> <p>IECEX Ex d IIC IECEX SIR 05.0042U</p>	
INGRESS PROTECTION	IP54, CSA Enclosure Type (NEMA) 3	
IMPACT RESISTANCE	7Nm	
OPERATING TEMPERATURES	-100°C to +600°C	
MATERIALS	Brass CZ121 (SPAB, SPBB) 316 Stainless Steel (SPAS, SPBS) Aluminium Alloy (SPAA, SPBA)	
THREADS	ISO Metric; ET; NPT; NPS; ISO Pipe Thread (BSP Taper, BSP Parallel); PG	
PLATING	Zinc (ZP); Nickel (NP); Tin (TP); Electroless Nickel (EN)	
EXAMPLE PART NUMBER	Sample: SPAB/NP/M20  SPA - Stopping Plug type (Externally accessible hexagon recess) B - Body material (Brass) NP - Nickel plating M20 - Male thread size	

SIZES AVAILABLE AND DIMENSIONAL REFERENCES							
Metric	Dim Ref	NPT	Dim Ref	ISO Pipe	Dim Ref	PG	Dim Ref
M16	B					7	A
M20	C	1/2"	D	1/2"	F	9	B
M25	C	3/4"	D	3/4"	F	11	C
M32	C	1"	E	1"	H	13.5	C
M40	C	1 1/4"	E	1 1/4"	H	16	C
M50	C	1 1/2"	E	1 1/2"	H	21	C
M63	C	2"	E	2"	H	29	C
M75	C	2 1/2"	G	2 1/2"	H	36	C
M80 x 2.0	G	3"	G	3"	H	42	C
M85 x 2.0	G	3 1/2"	G			48	C
M90 x 2.0	G	4"	G				
M100 x 2.0	G						

DIMENSIONS								
Dimension Reference	A	B	C	D	E	F	G	H
Hex Socket A/F	6.0	8.0	10.0	10.0	10.0	10.0	10.0	10.0
Length (min)	16.0	17.0	17.0	14.0	16.0	18.0	22.0	25.0

**All Dimensions are in Millimetres**

**NOTES:**

- Full installation instructions are supplied with stopping plugs, the instructions must be read prior to installation and adhered to in full
- Unless otherwise stated ISO Metric entry threads have a 1.5mm pitch
- For Flameproof Exd applications the female thread into which the stopping plug is to be fitted must comply with clause 5.3 of EN 50018:2000 (clause 5.3 IEC 79-1)
- For NEC/CEC Explosion Proof applications an engagement of at least 8 full threads must be achieved for parallel threads and 5 full threads must be achieved for tapered threads

<http://www.cableglands.com>

# Peppers Cable Glands Limited

Stanhope Road, Camberley, Surrey, GU15 3BT United Kingdom  
 Telephone: +44 (0) 1276 64232  
 Facsimile: +44 (0) 1276 691752  
 Email: sales@peppers.co.uk



## Accessories:- Breather Drain - Type ACDPE



Including type No's:

A	C	D	P	E	*
					B
					S
					N
					A

ACDPE Series Breather Drain provides a method of effectively draining any moisture within an enclosure whilst allowing the air inside the enclosure to breathe with the surrounding atmosphere. ACDPE series breather drains maintain Increased Safety Exe method of explosion protection and IP66 for IEC type applications.

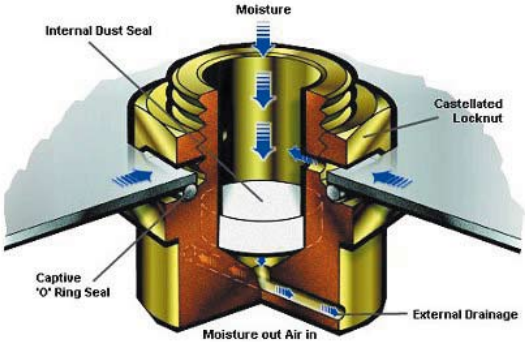
<p><b>CERTIFICATION</b></p>	<p><b>CENELEC</b>                  SIRA99ATEX3050U I M2 II 2DG EExe I/II; II 2DG E Exe (Glass Filled Nylon and Aluminium)</p> <p><b>CSA / A Ex</b>                  Class I, Zone 1, Exe II; Class I Division 2, Groups ABCD</p> <p><b>GOST R-Exe II</b>                  POCC GB MTT14.B00030</p> <p><b>IECEX Ex e II</b>                  IECEX SIR 08.00244</p>	
<p><b>APPLICATION</b></p>	<p><b>Internal Dust Seal</b> provides ingress protection to IP66 and 4x, with the largest possible pore size to aid draining, whilst retaining filtration capabilities that remove debris from the moisture and retains it on the surface where it can easily be removed with compressed air. Additionally the structural strength and chemical resistance characteristics of the material enable the filter to meet the requirements of hazardous area installations</p> <p><b>Castellated Locknut</b> allows moisture to pass between the locknut and the enclosure, draining via holes in the thread without any build up of moisture in the bottom of the enclosure</p> <p><b>Captive 'O' Ring Seal</b> is located within a recess on the face of the breather drain again optimising ingress protection, ensuring the 'o'ring is not displaced during installation and helping protect the 'O' ring from the environmental damage</p> <p><b>External Drainage</b> via two ports optimises ingress protection without compromising the draining capabilities</p>	
<p><b>INGRESS PROTECTION</b></p>	<p>IP66, CSA Enclosure Type 4x, NEMA 4x</p>	
<p><b>IMPACT RESISTANCE</b></p>	<p>20Nm. (7Nm GF Nylon and Aluminium)</p>	
<p><b>OPERATING TEMPERATURES</b></p>	<p>-50°C to +85°C</p>	
<p><b>MATERIALS</b></p>	<p>Brass CZ121 (ACDPEB)                  316 Stainless Steel (ACDPES)                  Aluminium Alloy (ACDPEA)                  30% Glass Filled Nylon (ACDPEN)</p>	
<p><b>VARIATIONS</b></p>	<p>Clearance hole (10): 10mm length of thread, supplied complete with a castellated locknut and having 2 holes in the thread wall positioned directly opposite each other</p> <p>Threaded Entry: 15mm length of thread, either supplied with or without castellated locknut and having 3 holes in the thread wall, offset to provide a 9mm range to accommodate differing wall thickness'</p>	
<p><b>THREADS</b></p>	<p>ISO Metric; NPT; NPS; ISO Pipe Thread (BSP Taper, BSP Parallel); PG</p>	
<p><b>SEALS</b></p>	<p>The standard 'O' Ring material is Nitrile</p>	
<p><b>PLATING</b></p>	<p>Zinc (ZP); Nickel (NP); Tin (TP); Electroless Nickel (EN)</p>	

EXAMPLE PART NUMBER	<p>Sample: ACDPEB/NP/M20/15  ACDPEB - Breather Drain type and material (Brass)</p> <p><b>NP</b> - Nickel plating  <b>M20</b> - Male thread size  <b>15</b> - Male thread length (15mm) and drain holes in thread (x 3 offset)</p>
---------------------	---

DIMENSIONAL DATA				
Size	Hex A/F	Hex A/C	Thread Length	Head Length
M20 - 1/2" NPT	28.6mm	32.9mm	10 (2 Hole) or 15 (3 Hole)	15mm
M25 - 3/4"NPT	34.9mm	40.2mm		
All Dimensions are in Millimetres				

**NOTES:**

- 30% glass filled nylon variations are only available with 15mm length of thread version and are supplied with or without a brass castellated nut
- Installation instructions are supplied with the breather drain, the instructions must be read prior to installation and adhered to in full
- Unless otherwise stated ISO Metric entry threads have a 1.5mm pitch
- Where metallic breather drains are fitted into non-metallic Increased Safety Exe enclosures they must be included within the earth circuit of the system

<http://www.cableglands.com>

## Peppers Cable Glands Limited

Stanhope Road, Camberley, Surrey, GU15 3BT United Kingdom  
 Telephone: +44 (0) 1276 64232  
 Facsimile: +44 (0) 1276 691752  
 Email: sales@peppers.co.uk



### Accessories:- General



Part of our Accessories Range  
 2008 Catalogue Page 7.4.1

A full range of accessories including locknuts, earthtags, sealing washers, serrated washers and shrouds for use with all our cable glands

#### AVAILABILITY

ACCESSORY TYPE	GLAND TYPES/SIZE	THREAD TYPES				
		METRIC	NPT	BSP	PG	FRENCH
<b>Locknuts</b> provide a method of securing a threaded entry component into a piece of equipment						
Brass (ACBLN)	All	M16 to M100	1/2" to 4"	1/2" to 4"	PG7 to PG48	F48
316 Stainless Steel (ACSLN)	316 Stainless Steel	M16 to M100	1/2" to 4"	1/2" to 4"	PG7 to PG48	F48
Aluminium Alloy (ACALN)	Aluminium	M20 to M63	-	-	-	-
Nylon (ACNLN)	Nylon	M20 to M63	-	-	PG7 to PG48	-
<b>Earth Tags</b> provide an earth bond connection for an entry component						
Brass (ACBET)	All	M16 to M100	1/2" to 4"	1/2" to 4"	PG7 to PG48	F48
Aluminium Alloy (ACAET)	Aluminium	M20 to M63	-	-	-	-
<b>IP Sealing Washers</b> are fitted between an entry component and the equipment to maintain the IP rating of the equipment						
Nylon (ACNSW)	All	M16 to M100	1/2" to 4"	1/2" to 4"	PG7 to PG48	F48
Red Fibre (ACFSW)	All	M20 to M75	-	-	-	-
<b>Serrated Star Washers</b> can be used in conjunction with a locknut to provide additional fixing security and improve bonding						
316 Stainless Steel (ACSSW)	All	M16 to M100	1/2" to 4"	1/2" to 4"	PG7 to PG48	F48
<b>Shrouds</b> can be used to protect the gland from the surrounding environment						
PVC (ACSPVC)	16 to 100	Shrouds are not available for all glands, please see specific gland page for exact details				
PCP (ACSPCP)	16 to 85					
LSOH (ACSSIO)	16 to 85					

- NOTES:
- As standard ISO Metric threads are supplied with a 1.5mm pitch up to and including M75 and a 2.0mm pitch for sizes above M75



# Peppers Cable Glands Limited

Stanhope Road, Camberley, Surrey, GU15 3BT United Kingdom

Telephone: +44 (0) 1276 64232

Facsimile: +44 (0) 1276 691752

Email: sales@peppers.co.uk



## Entry Thread Reference Tables

Thread Types	Thread Ref	Size	Major Ø	TPI	Pitch	Thread Length	Min Hex A/C
ISO METRIC IEC 60423 1993	M16	16 x 1.5	15.97	16.93	1.50	16.0	26.5
	M20	20 x 1.5	19.97	16.93	1.50	16.0	33.0
	M25	25 x 1.5	24.97	16.93	1.50	16.0	41.4
	M32	32 x 1.5	31.97	16.93	1.50	16.0	50.6
	M40	40 x 1.5	39.97	16.93	1.50	16.0	60.4
	M50	50 x 1.5	49.97	16.93	1.50	16.0	71.5
	M63	63 x 1.5	62.97	16.93	1.50	19.0	88.0
	M75	75 x 1.5	74.97	16.93	1.50	19.0	99.0
	M80	80 x 2.0	79.97	12.70	2.00	25.0	115.2
	M85	85 x 2.0	84.97	12.70	2.00	25.0	115.2
M90	90 x 2.0	89.97	12.70	2.00	25.0	125.7	
M100	100 x 2.0	99.97	12.70	2.00	25.0	125.7	
NPT ANSI B1.20.1 1983	050NPT	1/2"	21.34	14.00	1.81	19.9	26.5
	075NPT	3/4"	26.67	14.00	1.81	20.1	33.0
	100NPT	1"	33.40	11.50	2.20	25.0	41.4
	125NPT	1 1/4"	42.16	11.50	2.20	25.6	50.6
	150NPT	1 1/2"	48.26	11.50	2.20	26.0	60.5
	200NPT	2"	60.33	11.50	2.20	26.9	71.5
	250NPT	2 1/2"	73.03	8.00	3.18	39.9	88.0
	300NPT	3"	88.90	8.00	3.18	41.5	99.0
	350NPT	3 1/2"	101.60	8.00	3.18	42.8	115.2
	400NPT	4"	114.30	8.00	3.18	44.0	125.7
NPS ANSI B1.20.1 1983	050NPS	1/2"	20.90	14.00	1.81	19.9	26.5
	075NPS	3/4"	26.26	14.00	1.81	20.1	33.0
	100NPS	1"	32.84	11.50	2.20	21.5	41.4
	125NPS	1 1/4"	41.61	11.50	2.20	25.6	50.6
	150NPS	1 1/2"	47.67	11.50	2.20	26.0	60.5
	200NPS	2"	59.72	11.50	2.20	26.9	71.5
	250NPS	2 1/2"	72.16	8.00	3.18	39.9	88.0
	300NPS	3"	88.06	8.00	3.18	41.5	99.0
	350NPS	3 1/2"	100.78	8.00	3.18	42.8	115.2
	400NPS	4"	113.43	8.00	3.18	44.0	125.7
PG DIN 40430 1971 (W/D)	PG7	PG7	12.50	20.00	1.27	16.0	26.5
	PG9	PG9	15.20	18.00	1.41	16.0	26.5
	PG11	PG11	18.60	18.00	1.41	16.0	26.5
	PG13.5	PG13.5	20.40	18.00	1.41	16.0	26.5
	PG16	PG16	22.50	18.00	1.41	16.0	33.0
	PG21	PG21	28.30	16.00	1.59	16.0	41.4
	PG29	PG29	37.00	16.00	1.59	16.0	50.6
	PG36	PG36	47.00	16.00	1.59	16.0	60.5
	PG42	PG42	54.00	16.00	1.59	16.0	71.5
	PG48	PG48	59.30	16.00	1.59	16.0	88.0
ISO Pipe Parallel ISO R/7; BS2779 (BSPP, G, R, PF)	F48	PG48 (FR)	59.61	11.00	2.31	26.9	71.5
	050BSP	1/2"	20.96	14.0	1.81	19.9	26.5
	075BSP	3/4"	26.44	14.0	1.81	20.1	33.0
	100BSP	1"	33.25	11.0	2.31	25.0	41.4
	125BSP	1 1/4"	41.91	11.0	2.31	25.6	50.6
	150BSP	1 1/2"	47.80	11.0	2.31	26.0	60.5
	200BSP	2"	59.61	11.0	2.31	26.9	71.5
	250BSP	2 1/2"	75.18	11.0	2.31	39.9	88.0
ISO Pipe Taper to ISO R/7; BS21 (BSPT, GK)	050BST	1/2"	20.96	14.0	1.81	19.9	26.5
	075BST	3/4"	26.44	14.0	1.81	20.1	33.0
	100BST	1"	33.25	11.0	2.31	25.0	41.4
	125BST	1 1/4"	41.91	11.0	2.31	25.6	50.6
	150BST	1 1/2"	47.80	11.0	2.31	26.0	60.5
	200BST	2"	59.61	11.0	2.31	26.9	71.5
250BST	2 1/2"	75.18	11.0	2.31	39.9	88.0	

## Peppers Cable Glands Limited

Stanhope Road, Camberley, Surrey, GU15 3BT United Kingdom  
 Telephone: +44 (0) 1276 64232  
 Facsimile: +44 (0) 1276 691752  
 Email: sales@peppers.co.uk



### Ingress Protection

It is essential when selecting cable glands and/or accessories to ensure that the products will maintain the IP rating of the equipment and the integrity of the installation.

**IP Codes are based on the IEC Standard 529, degrees of protection provided by enclosures.**

In most cases Peppers cable glands will maintain Ingress Protection of the equipment into which they are installed to:

<b>IP 66</b>	<ul style="list-style-type: none"> <li>● Dust tight. No ingress of dust possible</li> <li>● Protected against heavy seas or powerful jets of water. Prevents ingress sufficient to cause harm</li> </ul>
<b>IP 67</b>	<ul style="list-style-type: none"> <li>● Dust tight. No ingress of dust possible</li> <li>● Protected against harmful ingress of water when immersed between a depth of 150mm to 1m</li> </ul>
<b>IP 68</b>	<ul style="list-style-type: none"> <li>● Dust tight. No ingress of dust possible</li> <li>● Protected against submersion. Suitable for continuous immersion in water at stated depth</li> <li>● (Unless specified to the contrary, depth stated for Peppers cable glands = 25m)</li> </ul>
<b>DTS 01 (Deluge)</b>	<ul style="list-style-type: none"> <li>● This test was originally constructed by Shell and Esso in the UK to simulate the routine deluging of electrical equipment on offshore installations</li> </ul>

The minimum requirements for Hazardous Location products is:

<b>IP 54</b>	<ul style="list-style-type: none"> <li>● Dust protected. Prevents ingress of dust sufficient to cause harm.</li> <li>● Protected from splashing water from any direction.</li> </ul>
--------------	--

As a general guide to selecting the sealing method that is most likely to maintain the required IP rating for different entry types, we recommend:

- Clearance Holes - Integral 'O' ring seal or nylon IP washer
- Parallel Threaded Entries - Integral 'O' ring seal, IP washer or non-hardening thread sealant
- Taper Threaded Entries - Non-hardening thread sealant

### Gland Weight Data

Gland Size	Entry Thread	Cable Gland Type										
		CR-1B	E1WF	CWLE	A2LF	A2LDSF	RG22E	CR-CB	CR-XB	CR-UB	CR-SB	BW
16	M20	164	144	134	84	142	6	165	-	-	-	-
20s	M20	160	130	124	90	144	-	165	115	180	-	52
20	M20	250	186	180	94	158	8	240	170	260	215	84
25	M25	400	262	262	152	256	16	400	260	385	340	140
32	M32	750	420	402	176	298	28	725	384	570	485	180
40	M40	1095	672	680	332	556	35	1060	585	885	730	436
50s	M50	1415	980	1040	570	980	-	1435	-	1035	-	-
50	M50	1295	758	764	458	796	65	1340	700	1160	875	480
63s	M63	2345	1410	1410	850	1410	-	2100	-	1555	-	-
63	M63	2008	1140	1185	684	1170	74	2025	1040	1695	1355	910
75s	M75	1980	1745	1730	954	1565	-	2330	-	1750	-	-
75	M75	2200	1375	1495	764	1310	-	2240	1150	1880	1475	1070
80	M80	3970	3255	3130	1430	2130	-	4985	2730	3860	3415	1770
85	M85	3300	2655	2500	1290	1980	-	4065	2255	3250	2830	-
90	M90	4314	3559	3280	1510	2360	-	5215	2790	3985	3985	-
100	M100	3537	2795	3054	1485	2285	-	4410	2450	3580	3580	-

All weights are approximate and shown in grams

#### NOTES:

- Weights shown are for Brass versions (except Nylon RG22E)
- To estimate weights for 316 Stainless Steel versions apply a factor of 0.92
- To estimate weights for Aluminium versions apply a factor of 0.32
- Weights for glands with non-metric entry threads will vary
- Approximate weights for A2LC\*F, E8XF, A8F are available on application
- Approximate weights for E1W, CWL and A2L industrial glands are the same as for Ex versions



## **HEALTH & SAFETY**

When used and installed as prescribed within the data sheets provided, Peppers Cable Glands products will not cause any danger or hazard to the health or safety of persons, animals or property. The products should be installed by suitably trained/skilled personnel and in full accordance with the relevant legislative regulations (including the UK's IEE wiring regulations) and the accepted rules for the industry concerned.

## **WARNING**

Peppers' cable glands should not be used within any application other than those specified for each product, unless Peppers Cable Glands issue a statement in writing that the product is suitable for the specified application. For further information on each product, we refer you to the specific Assembly Instructions and General Arrangement drawings, which are available on request. Using the links on our web site catalogue pages and instructions may be downloaded from the internet. Peppers Cable Glands take no responsibility for any damage, injury or other consequential loss caused where the glands are not installed or used according to our Assembly Instructions.

## **HAZARDOUS AREA INSTALLATION**

When selecting equipment for use in the hazardous areas the appropriate national or international standards or codes of practice must be considered.

## **GENERAL SUITABILITY FOR THE INSTALLATION ENVIRONMENT**

Peppers' cable glands are designed for normal industrial environments with regard to temperature, humidity and vibration. Construction materials include steel, brass and aluminium alloys, and neoprene, nitrile and silicone rubbers. To minimise galvanic corrosion, the metallic gland components are made from similar materials. Material compatibility under chemical corrosion or attack by aggressive substances must be considered before installation.

## **SPARE PARTS**

Apart from the accessories listed in this catalogue, Peppers does not supply spare parts for any of its glands. Glands are designed so that no part from another manufacturer's gland will fit Peppers' gland. If part of a gland needs to be replaced for any reason, the user should ensure an entire new gland is fitted.

## **DIMENSIONAL DATA**

The dimensions shown within this catalogue may vary due to material availability.

## **CE CONFORMITY**

Copies of Peppers CE declarations regarding LVD, EMC and ATEX directives are available upon request. BS EN 50262 classification with regard to mechanical and electrical properties of cable glands is available upon request.

## **TERMS & CONDITIONS**

Full terms and conditions of sale are available upon request.



whatever the hazard

Global Approvals • Universal Solutions



Quality Products • Accurate Advice • Unbeatable Service

*ATEX • CENELEC • IECEx • GOST • CSA • UL • NEPSI • ISO 9001:2000*

**[www.cableglands.com](http://www.cableglands.com)**

# www.cableglands.com

ATEX • CENELEC • IECEx • GOST • CSA • UL • NEPSI • ISO 9001:2000

Your local Agent or Distributor



**Peppers Cable Glands Limited**

Stanhope Road, Camberley, Surrey, GU15 3BT, Great Britain

Tel: +44 (0) 1276 64232 • Fax: +44 (0) 1276 691752 • Email: sales@peppers.co.uk